

# ATRA-FLEX<sup>®</sup>

Flexible Couplings

*Leaders in Design Technology*

## Product Catalog

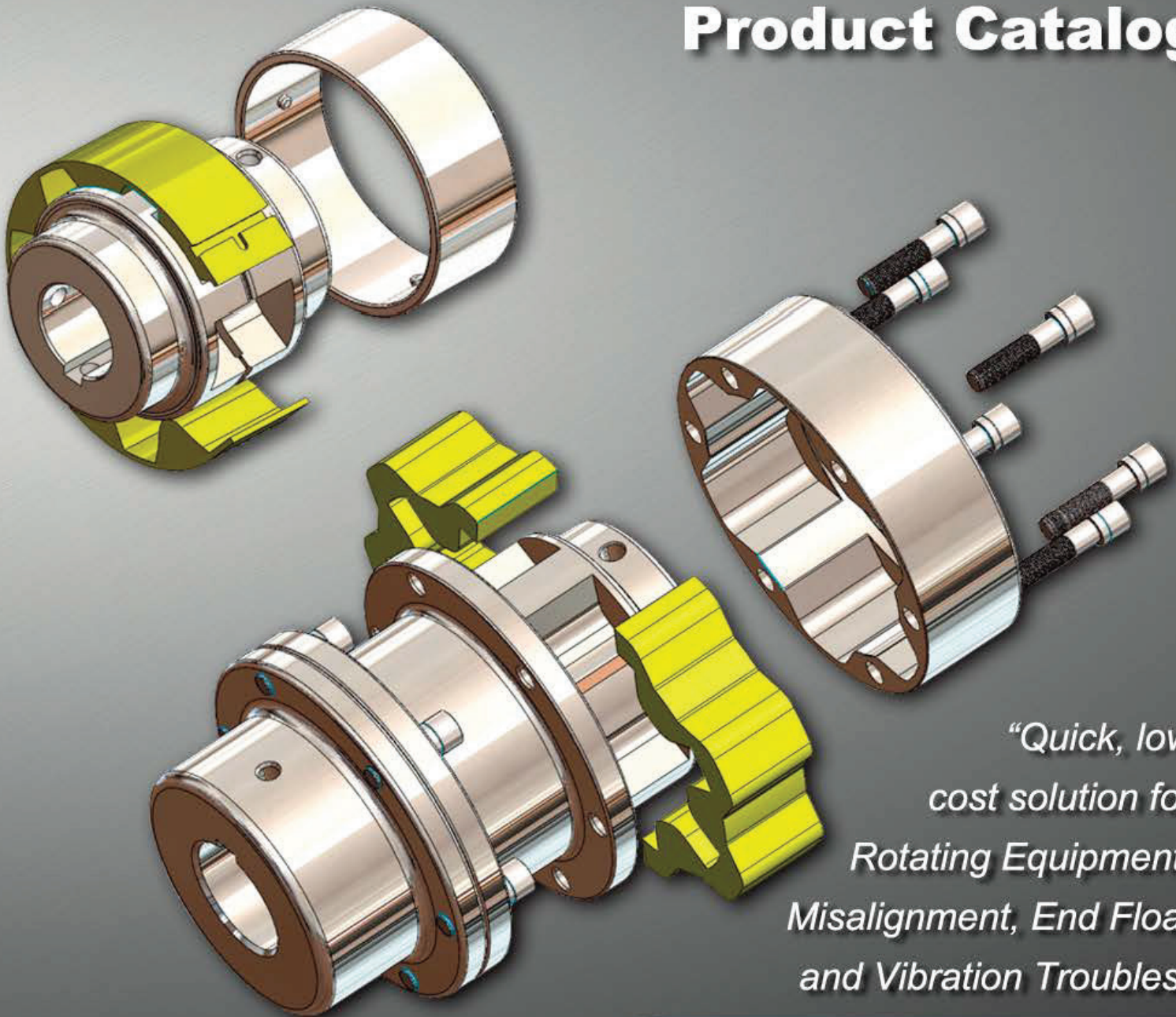

*“Quick, low  
cost solution for  
Rotating Equipment,  
Misalignment, End Float  
and Vibration Troubles.”*

[www.Atra-Flex.com](http://www.Atra-Flex.com)



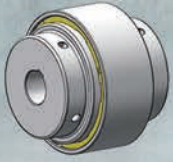

**Millennium Non-Spacer**  
page 3

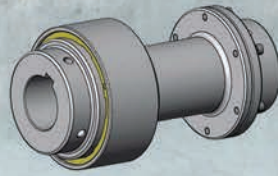

**Millennium Spacer**  
page 4

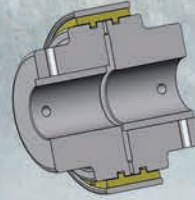

**Millennium Limited End Float**  
page 5

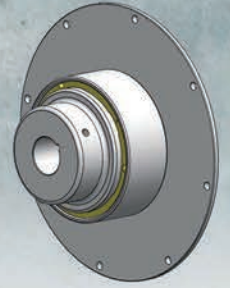

**Millennium Flywheel**  
page 6



**Millennium Drop-Out Spacer**  
page 7

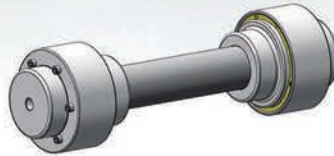

**Millennium Floating Shaft**  
page 8

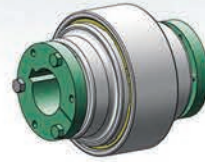

**Millennium Bushings**  
page 9



**T-Flex Non-Spacer**  
page 12



**T-Flex Spacer**  
page 12



**T-Flex Limited End Float**  
page 13

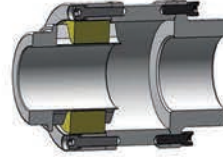

**T-Flex Axial Slide**  
page 14

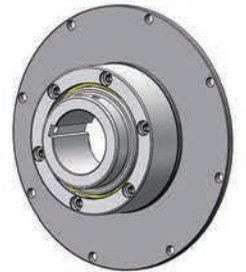

**T-Flex Flywheel**  
page 15



**T-Flex Floating Shaft**  
page 16



**T-Flex BrakeWheel**  
page 17



**T-Flex Brake Disc**  
page 17



**T-Flex Bushings**  
page 18

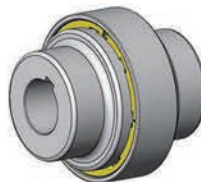

**A-Series Non Spacer**  
page 21

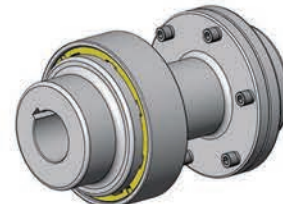

**A-Series Spacer**  
page 22

**ATRA-FLEX ADVANTAGES**  
page 1

**MILLENNIUM QUICK SELECTION**  
page 2

**T-FLEX ADVANTAGES**  
page 10

**T-FLEX QUICK SELECTION**  
page 11

**T-FLEX TECHNICAL**  
page 19

**A-SERIES QUICK SELECTION**  
page 21

**TECHNICAL ATRA-FLEX**  
page 23

**SELECTION GUIDE ATRA-FLEX**  
page 24

**SOLVING MISALIGNMENT**  
page 25



**ATRA-FLEX** means savings in manpower and downtime, easy installation, economy and long, trouble-free service

Now there's a new solution to one of the most persistent and troublesome problems facing maintenance personnel - periodic coupling failure and the downtime and expense that go with it. If a new insert is needed, a low-cost replacement can be installed in minutes without moving either the prime mover or the driven equipment.

There are only four parts in ATRA-FLEX couplings. The two identical hubs (number 1 and 2, right) are made of steel, each with four, six or eight teeth, depending on load and size. The split insert (number 3), which is made of specially compounded polyurethane, fits between the hubs. The outer steel holding ring (number 4) has no nuts or bolts!

## Assembly and disassembly

After hubs (1) and (2) and holding ring (4) are installed on shafts, the teeth are then aligned parallel to each other, but not touching. Once installed the hubs never need to be moved again. The elastic insert (3) can then be installed in the slots formed by the parallel teeth. When the insert is in position, slide holding ring (4) onto the polyurethane insert starting, centrifugal force will expand the elastic insert to fix it tightly to the inside of the steel ring.

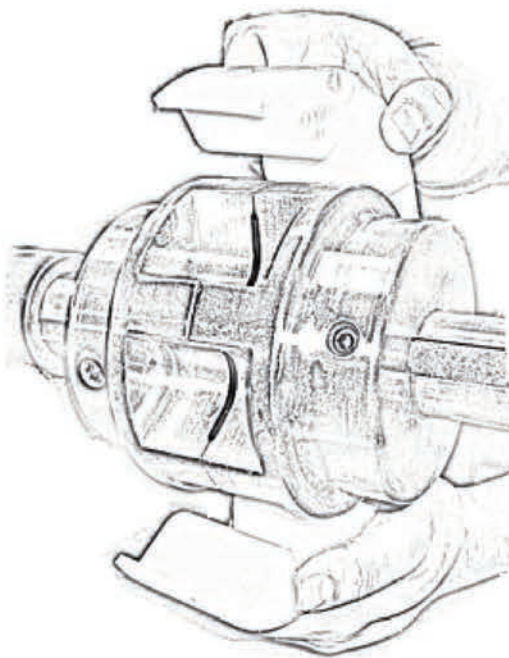

## ATRA-FLEX® offers all these advantages

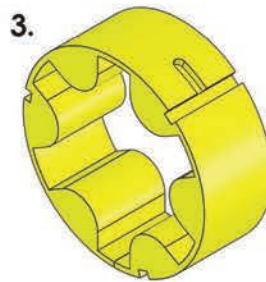
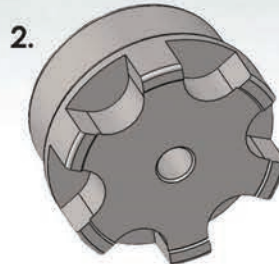
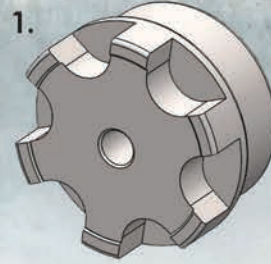

- Changeout of coupling insert is faster than any other.
- Custom compounded polyurethane inserts provide elasticity and resistance to high torque, shear and shock loads
- Unlike others, a single ATRA-FLEX coupling can be purchased to fit two different shaft sizes.
- Elastic insert is highly resistant to humidity, oils, corrosion and chemicals; retains performance characteristics at temperatures from -60°F to +250°F.
- No lubrication or service is required.
- ATRA-FLEX couplings have run 70,000 hours and more with no signs of wear.
- ATRA-FLEX couplings may be installed horizontally or vertically; can rotate in either direction.
- No bolts or sharp edges provide safer operation.
- Operation is completely silent at all speeds and loads.
- No metal-to-metal contact between coupling parts.
- Initial cost is low, and maintenance and downtime are minimal.
- High temperature insert (red) available up to +350° F.
- Melonite Process available for enhanced corrosion and wear resistance. Low cost alternative to stainless steel.

To disassemble, remove the ring  
The insert can then be quickly and easily removed and replaced. No special tools, screws, bolts or other fasteners needed.

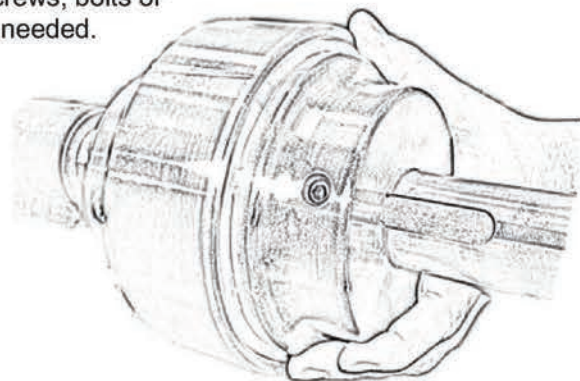



- 1) Determine service factor (SF)  
SF = F1 X F2 (not to exceed 4)

DRIVER F1	SF
ELECTRIC MOTOR	1.0
GAS OR STEAM TURBINE	1.0
GEAR BOX INCREASER / REDUCER	1.0
GAS OR DIESEL ENGINE 4+ CYL	3.0
GAS OR DIESEL ENGINE 1-3 CYL	4.0

- 2) Calculate required coupling continuous torque rating (lb-in) using the formula: HP X SF X 63025 ÷ RPM = Torque (lb-in)

DRIVER F2	SF
GENERATORS, GEAR BOXES, LIGHT DUTY AGITATORS & CONVEYERS, STOKERS	1.0
CENTRIFUGAL PUMPS, COMPRESSORS, BLOWERS, FANS, ETC.	1.0
RECIPROCATING PUMPS, COMPRESSORS, FEEDERS, FREQUENT STOPS/STARTS, ETC.	2.0
PULP & PAPER MILL EQUIPMENT (REFER TO MILL STANDARD COUPLING SF GUIDE)	1-3
STEEL MILL EQUIPMENT (REFER TO MILL STANDARD COUPLING SF GUIDE)	1-3

- 3) Determine suitable coupling insert type for application using the Insert Color Chart below

INSERT TYPE	DESCRIPTION	USE	MAX TEMP °F	MIN TEMP °F	DUROMETER
YELLOW	GENERAL USE, HIGH DAMPEN	GENERAL APPLICATIONS (STANDARD)	250	-60	60 D
RED	HIGH TEMPERATURE, HIGH DAMPEN	HIGH TEMPERATURE RUNNING APPLICATIONS	350	20	90 A
ORANGE	HIGH TORQUE, MEDIUM DAMPEN	HIGH TORQUE, LOW SPEED APPLICATIONS	250	-20	70 D
GREEN	EXTRA HIGH DAMPENING	ENGINE OR RECIPROCATING WITH HIGH VIBRATORY TORQUES	250	-60	90 A

- 4) Choose the coupling size that meets or exceeds the calculated required continuous torque rating using the color coded tables below. Intermittent (peak) ratings are reserved for system torque spikes, starts/stops, reversing etc.

Insert Tables: Torque ratings (lb-in) - HP ratings @ various RPMs - Max RPM's based on insert types

INSERT YELLOW	M00	M0	M1	M1 H	M2	M3	M4	M5	M6	M7	M8	M9	M10	M12	M13
CONTINUOUS (LB-IN)	180	600	1260	2400	3000	5760	12600	28800	48000	111000	186600	273000	420000	960000	1900000
INTERMITTENT (LB-IN)	300	1000	2100	4000	5000	9600	21000	48000	80000	185000	311000	455000	700000	1600000	3200000
HP @ 100 RPM (SF1)	0.29 0.48	0.95 1.39	2.00 3.33	3.81 6.35	4.76 7.93	9.14 15.23	20 33	46 76	76 127	176 294	296 493	433 722	666 1111	1523 2539	3015 5077
HP @ 1200 RPM (SF1)	3.43 5.71	11.42 19.04	23.99 40	45.70 76.16	57 95	110 183	240 400	548 914	914 1523	2113 3522	3553 5921	5198 8663	7997 13328	18278 30464	36176 90928
HP @ 1750 RPM (SF1)	5.00 8.33	16.66 27.77	35 58	66.64 111.07	83 139	160 297	350 583	800 1333	1333 2221	3082 5137	5181 8635	7580 12634	11662 19437	26656 44427	
HP @ 3600 RPM (SF1)	10.28 17.14	24.27 57.12	72 120	137.09 228.48	171 286	329 548	720 1200	1645 2742	2742 4570	6340 10567	10659 17764	15594 25990	23990 39984	54835 91392	
MAX RPM BALANCED G2.5	20200	12200	11000	9000	8800	7000	5300	4200	3400	2900	2400	2100	1900	1400	1100
MAX RPM UNBALANCED	13483	8100	7280	6500	5800	4700	3600	2800	2300	2000	1700	1450	1300	960	700

INSERT RED	M00	M0	M1	M1 H	M2	M3	M4	M5	M6	M7	M8	M9	M10	M12	M13
CONTINUOUS (LB-IN)	153	510	1071	2040	2550	4896	10710	24480	40800	94350	158610	232050	357000	816000	1615000
INTERMITTENT (LB-IN)	255	850	1765	3400	4250	8160	17650	40800	68000	157250	264350	386750	595000	1360000	2720000
HP @ 100 RPM (SF1)	0.25 0.41	0.81 1.35	1.70 2.63	3.24 5.40	4.05 6.74	7.77 12.95	17 28	39 65	65 108	150 250	282 419	368 614	566 944	1295 2158	2563 4315
HP @ 1200 RPM (SF1)	2.92 4.85	9.71 16.18	20.39 34	38.85 64.74	48 81	94 156	204 340	466 777	777 1295	1796 2994	3020 5033	4418 7364	6797 11329	15536 25894	30750 77289
HP @ 1750 RPM (SF1)	4.25 7.08	14.16 23.60	30 49	56.64 94.41	71 118	136 252	298 496	680 1133	1133 1888	2620 4366	4404 7340	6443 10739	9913 16521	22658 37763	
HP @ 3600 RPM (SF1)	8.74 14.57	20.63 48.55	61 102	116.53 194.21	145 243	280 466	612 1020	1398 2331	2331 3865	5389 8982	9060 15099	13255 10739	20392 33986	46610 77663	
MAX RPM BALANCED G2.5	20200	12200	11000	9000	8800	7000	5300	4200	3400	2900	2400	2100	1900	1400	1100
MAX RPM UNBALANCED	13498	8100	7280	6500	5800	4700	3600	2800	2300	2000	1700	1450	1300	960	700

INSERT ORANGE	M00	M0	M1	M1 H	M2	M3	M4	M5	M6	M7	M8	M9	M10	M12	M13
CONTINUOUS (LB-IN)	342	1140	2394	4560	5700	10944	23940	54720	91200	210900	354540	518700	798000	1824000	3610000
INTERMITTENT (LB-IN)	570	1900	3990	7600	9500	18240	39900	91200	152000	351500	590900	864300	1330000	3040000	6080000
HP @ 100 RPM (SF1)	0.54 0.90	1.81 3.01	3.80 6.33	7.24 12.06	9.04 15.07	17.36 28.94	38 63	87 145	145 241	335 558	563 938	823 1372	1266 2110	2894 4823	5728 9647
HP @ 1200 RPM (SF1)	6.51 10.85	21.71 36.18	45.58 76	86.82 144.70	109 181	208 347	456 760	1042 1736	1736 2894	4016 6693	6750 11251	9876 16460	15194 25323	34729 57862	68735 115764
HP @ 1750 RPM (SF1)	9.50 15.83	31.65 52.76	66 111	126.62 211.03	158 264	304 506	665 1108	1519 2532	2532 4221	5856 9760	9844 16407	14403 24004	22198 36930		
HP @ 3600 RPM (SF1)	19.54 32.56	32.56 65.12	137 228	260.47 434.11	326 543	625 1042	1367 2279	3126 5209	5209 8682						
MAX RPM BALANCED G2.5	20200	12200	11000	9000	8800	7000	5300	4200	3400	2900	2400	2100	1900	1400	1100
MAX RPM UNBALANCED	13483	8100	7280	6500	5800	4700	3600	2800	2300	2000	1700	1450	1300	960	700

INSERT GREEN	M00	M0	M1	M1 H	M2	M3	M4	M5	M6	M7	M8	M9	M10	M12	M13
CONTINUOUS (LB-IN)	88	293	614	1170	1463	2808	6143	14040	23400	54113	90668	133088	204750	468000	96250
INTERMITTENT (LB-IN)	146	488	1024	1950	2438	4680	10238	23400	39000	90188	151613	221813	341250	780000	1560000
HP @ 100 RPM (SF1)	1.14 0.23	0.47 0.77	0.98 1.63	1.86 3.10	2.32 3.87	4.46 7.43	10 17	23 38	38 62	86 143	144 241	212 352	325 542	743 1236	1470 2475
HP @ 1200 RPM (SF1)	1.67 2.78	5.57 9.29	11.69 19.50	22.28 37.13	27.75 46.50	53 89	117 195	267 446	446 743	1031 1718	1732 2887	2534 4223	3899 6497	8911 14852	17636 29702
HP @ 1750 RPM (SF1)	2.44 4.06	8.12 13.54	17.25 28.50	32.49 54.14	40.50 67.50	78 130	170 284	390 650	650 1083	1502 2504	2526 4210	3695 6159	5685 9476		
HP @ 3600 RPM (SF1)	5.01 8.36	16.71 27.85	35.25 58.50	66.83 111.38	83.25 139.50	161 267	351 585	802 1337	1337 2226						
MAX RPM BALANCED G2.5	20200	12200	11000	9000	8800	7000	5300	4200	3400	2900	2400	2100	1900	1400	1100
MAX RPM UNBALANCED	13483	8100	7280	6500	5800	4700	3600	2800	2300	2000	1700	1450	1300	960	700

- 5) Determine coupling type required for the application. Check dimensions/max bore tables to confirm the coupling sized will accommodate shafts and physically fit the application. Determine if the couplings hubs will be bored to size, or used with Taper Lock Bushings, QD Bushings, or other type of locking device. Standard couplings are machined carbon steel. Specify if stainless steel or Melonite Process is required based on atmosphere conditions, etc.

Listed service factors are intended as a general guide, and are typical of usual service requirements. Please refer to AGMA 922-A96: Load Classification and Service Factors for Flexible Couplings for a complete list.



**ATRA-FLEX® Millennium®  
Non Spacer Couplings**

- Detect and Lock-On Ring Feature
- "Internal Support" of Insert for Higher Horse Power
- Higher Horse Power in a Smaller Package
- Larger Bore Capacity
- No Exposed Shaft on Spacer Coupling
- Very Economical

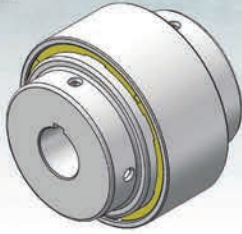

\*Limited End Float Couplings available please see LEF page

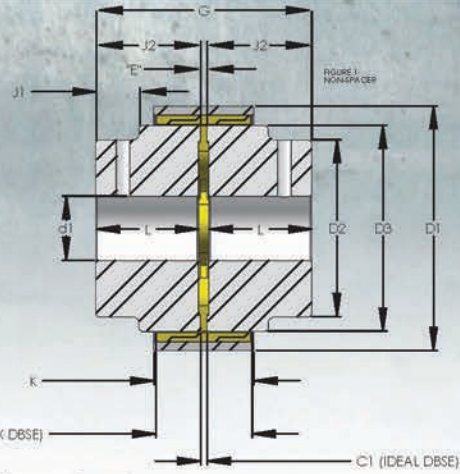

**DIMENSIONS - Millennium®**

SIZE	M00	M0	M1	M1H	M2	M3	M4	M5	M6	M7	M8	M9	M10	M11	M12	M13
EXTERNAL D1	2.170	2.840	3.860	4.345	4.820	5.750	7.600	9.700	11.800	13.600	15.850	17.860	19.875	23.030	27.350	34.620
TOTAL LENGTH G	2.050	2.825	3.575	3.950	4.575	5.075	6.700	9.200	11.200	12.200	14.700	18.200	20.200	22.250	23.250	22.300
MAXIMUM BORE	1.0	1.375	1.750	1.9375	2.250	2.500	3.375	4.500	5.500	6.000	7.2500	9.000	10.000	11.000	13.250	16.000
PILOT BORE d1	0.250	0.300	0.410	0.609	0.609	0.750	0.940	1.00	1.500	1.750	2.450	2.900	3.750	4.000	4.000	7.000
C1 (IDEAL DBSE)	.120	.175	.175	.175	.175	.175	.300	.320	.320	.320	.320	.320	.320	.372	.370	.500
C2 (MAX DBSE)	.600	1.00	1.400	1.685	1.500	2.000	2.800	3.200	3.800	5.000	6.000	6.250	6.500	7.000	9.000	9.000
L	0.965	1.375	1.700	1.888	2.200	2.450	3.200	4.440	5.440	5.940	7.190	8.940	9.940	10.940	11.450	10.900
D2	1.60	2.200	2.875	3.100	3.500	4.000	5.500	6.500	8.000	9.000	10.500	12.000	14.000	15.000	18.500	24.000
D3	1.70	2.400	3.150	3.470	3.900	4.900	6.400	8.180	9.930	11.800	13.940	15.900	17.870	19.650	23.850	30.000
J1	0.600	0.775	0.850	1.038	1.250	1.125	1.350	2.300	3.000	2.500	2.750	4.375	5.500	5.250	5.500	3.000
J2	1.000	1.375	1.750	1.938	2.250	2.500	3.250	4.500	5.500	6.000	7.250	9.000	10.000	11.000	11.500	11.000
K	0.720	1.145	1.570	1.575	1.600	2.1500	3.100	3.500	4.000	5.180	6.280	6.530	6.650	7.700	9.200	12.340
E (GAP)	.062	.075	.075	.075	.075	.075	.200	.200	.200	.200	.200	.200	.250	.250	.250	.300
APPROX. WT. (LBS)	0.75	2	4	5	10	19	36	72	125	190	320	475	964	1050	1200	1500

**Millennium Floater Couplings**



FLOATER SNAP

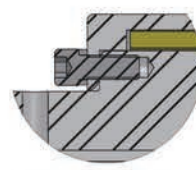
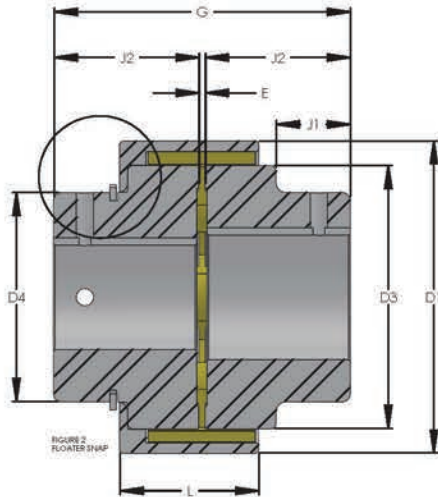

FLOATER BOLT

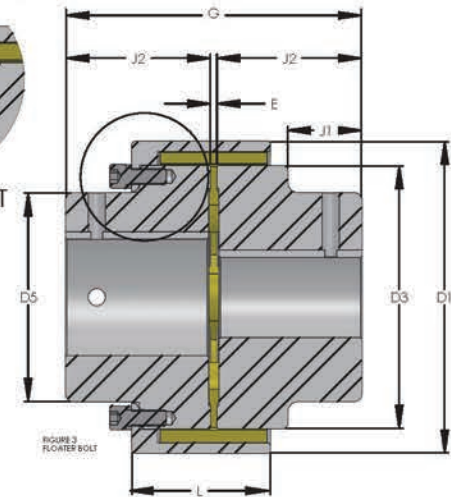

**DIMENSIONS - Millennium Floater®**

SIZE	M00	M0	M1	M1H	M2	M3	M4	M5	M6	M7	M8	M9	M10	M11	M12	M13
EXTERNAL D1	2.125	2.840	3.875	4.250	4.700	5.930	7.600	9.700	11.800	13.680	15.850	17.860	19.875	23.030	27.600	34.620
TOTAL LENGTH G	2.050	2.825	3.575	3.950	4.575	5.075	6.700	9.200	11.200	12.200	14.700	18.200	20.200	22.250	23.250	22.300
MAXIMUM BORE	1.0	1.375	1.750	1.9375	2.250	2.500	3.375	4.500	5.500	6.000	7.2500	9.000	10.000	11.000	13.250	16.000
PILOT BORE d1	0.250	0.300	0.500	0.609	0.609	0.750	0.940	1.00	1.500	1.750	2.450	2.900	3.750	4.000	4.000	7.000
D3	1.70	2.400	3.150	3.470	3.900	4.900	6.400	8.180	9.930	11.900	13.940	15.900	17.900	19.650	23.900	30.000
D4 (FSSO)	1.562	2.156	2.875	2.875	3.500	4.00	5.500	6.500	9.950	12.000	14.000	*	*	*	*	*
D5 (FSBO)	1.568	1.900	2.650	2.750	3.050	3.750	5.125	6.500	7.400	9.00	10.500	12.000	14.700	15.00	18.500	*
J1	0.600	0.775	0.850	1.038	1.250	1.125	1.350	2.300	3.000	2.500	2.750	4.375	5.500	5.250	5.500	3.000
J2	1.000	1.375	1.750	1.938	2.250	2.500	3.250	4.500	5.500	6.000	7.250	9.000	10.000	11.000	11.500	11.000
K	0.720	1.145	1.570	1.575	1.600	2.1500	3.100	3.500	3.900	5.180	6.280	6.530	6.650	7.700	9.200	12.340
E (GAP)	.062	.075	.075	.075	.075	.075	.200	.200	.200	.200	.200	.200	.250	.250	.250	.300
L	.900	1.355	1.875	1.928	2.048	2.635	3.780	4.310	5.060	6.625	8.250	8.500	8.470	9.735	9.200	*
APPROX. WT. (LBS)	0.75	2	4	5	10	19	36	72	125	190	320	475	964	1050	1200	1500



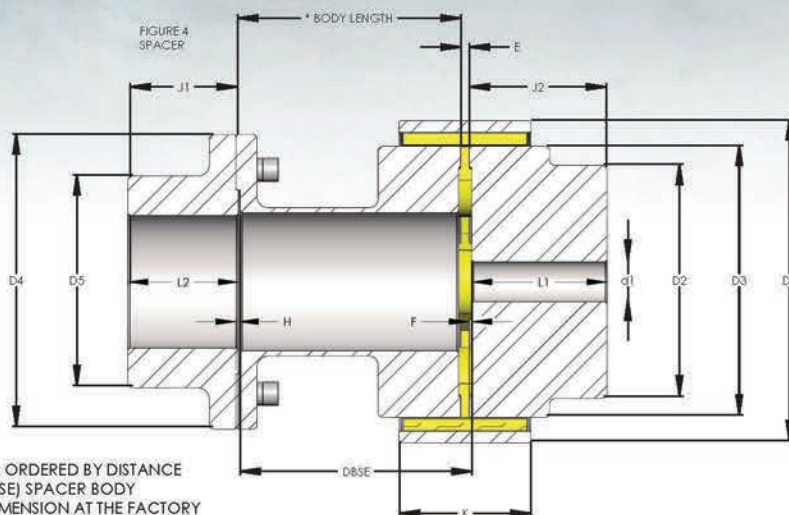
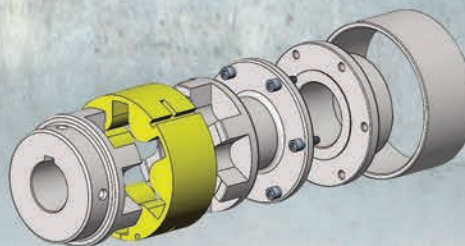
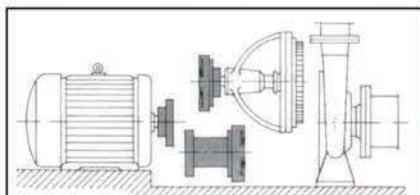
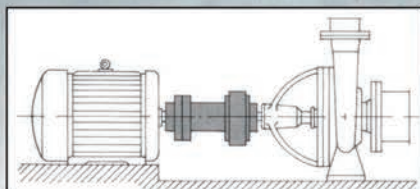

\*SPACER BODY LENGTH IS ORDERED BY DISTANCE BETWEEN SHAFT ENDS (DBSE) SPACER BODY SHORTENED BY THE "E" DIMENSION AT THE FACTORY

\*A-SERIES FLANGES ARE THE STANDARD FLANGE FOR MILLENNIUM SPACER COUPLINGS

**DIMENSIONS (IN INCHES) FOR Millennium® SPACER COUPLINGS**

SIZE	M00	M0	M1	M2	M3	M4	M5	M6	M7	M8	M9	M10	M11	M12
EXTERNAL D1	2.170	2.840	3.860	4.820	5.750	7.600	9.700	11.800	13.600	15.460	17.860	19.875	23.030	27.600
MAXIMUM BORE HUB	1.000	1.375	1.750	2.250	2.500	3.375	4.500	5.500	6.000	7.250	9.000	10.000	11.000	13.250
MAXIMUM BORE FLANGE HUB	0.875	1.375	1.875	2.250	2.875	3.375	4.000	5.000	5.750	7.125	8.250	10.500	11.000	14.250
*MAX BORE HEAVY DUTY FLANGE						3.875*	5.000*	6.875*	7.125*	8.875*	9.250*	11.875*		
PILOT BORE d1	0.250	0.300	0.500	0.609	0.750	0.940	1.000	1.500	1.750	2.450	2.900	3.750	N/A	4.000
L1	0.965	1.375	1.700	2.200	2.450	3.200	4.450	5.440	5.940	7.190	8.940	9.940	N/A	11.450
L2	1.025	1.438	1.620	2.125	2.411	2.610	3.410	4.312	4.625	7.00	9.100	11.100	9.812	11.625
D2	1.600	2.200	2.875	3.500	4.000	5.500	6.500	8.000	9.000	10.500	12.000	14.000	N/A	18.500
D3	1.700	2.400	3.150	3.900	4.900	6.400	8.180	9.930	11.800	13.940	15.900	17.870	19.650	23.850
D4	2.500	3.415	3.940	4.710	5.515	6.950	8.860	10.000	10.490	12.800	15.087	19.000	17.900	23.900
D5 (HEAVY DUTY FLANGE USE D4)	1.350	2.280	2.358	3.500	4.200	5.00	6.625	7.250	8.275	10.000	11.875	13.000	14.000	18.000
J1	1.088	1.375	1.562	1.940	2.315	2.548	3.350	4.250	4.500	7.000	9.000	11.000	9.750	11.500
J2	1.000	1.375	1.750	2.250	2.500	3.250	4.500	5.500	6.000	7.250	9.000	10.000	11.00	11.500
F	0.035	0.035	0.050	0.050	0.050	0.050	0.060	0.060	0.060	0.060	0.060	0.060		0.060
H	0.020	0.020	0.060	0.060	0.060	0.060	0.060	0.060	0.060	0.100	0.100	0.100	0.125	0.125
K	0.720	1.145	1.570	1.600	2.150	3.100	3.500	3.900	5.150	6.280	6.530	6.650	N/A	9.200
E (GAP)	.062	.075	.075	.075	.075	.200	.200	.200	.200	.200	.200	.250	N/A	.250
STANDARD BODY LENGTH	3.5	3.0 3.5	3.0 3.5 3.75 4.0 4.5 5.0	3.0 3.5 3.75 4.0 5.0 5.5 7.0	3.5 3.75 5.0 5.25 5.5 7.0 7.25 7.5	4.0 5.0 6.0 7.0 7.5 9.5 9.75	5.0 6.0 7.0 7.25 9.75 10.0 12.0	7.0 TO 14.0	7.0 TO 18.0	7.5 TO 18.0	9.5 TO 18.0	9.5 TO 20.0	9.5 TO 20.0	12.0 TO 24.0

CUSTOM LENGTHS AVAILABLE WITH EXTRA CHARGE

DROP OUT SPACER COUPLINGS TO CONVERT YOUR GREASE LUBRICATED GRID SPACER COUPLING TO A LOW MAINTENANCE ATRA-FLEX COUPLING AVAILABLE

NOTE: Use Table 2 (page 4) Horsepower Capacity at Various RPM.



**For Sleeve Bearing Motors, And All Other Applications Requiring Axial End-Float Restrictions**

(Meets API 610 Standards Maximum Coupling End Float Requirements)

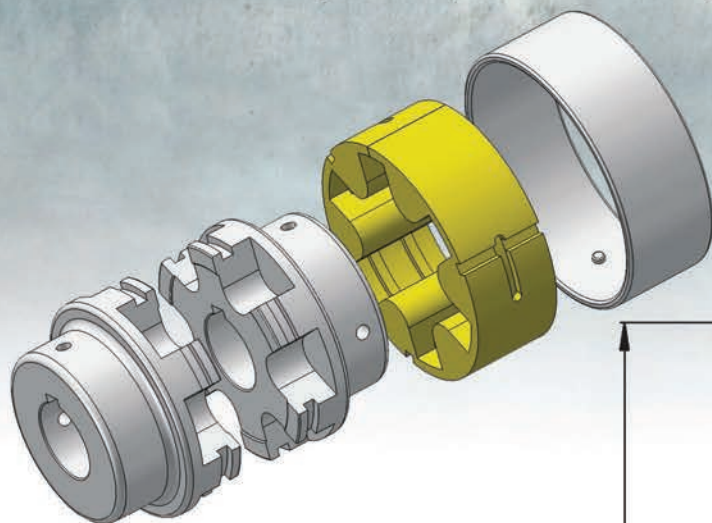
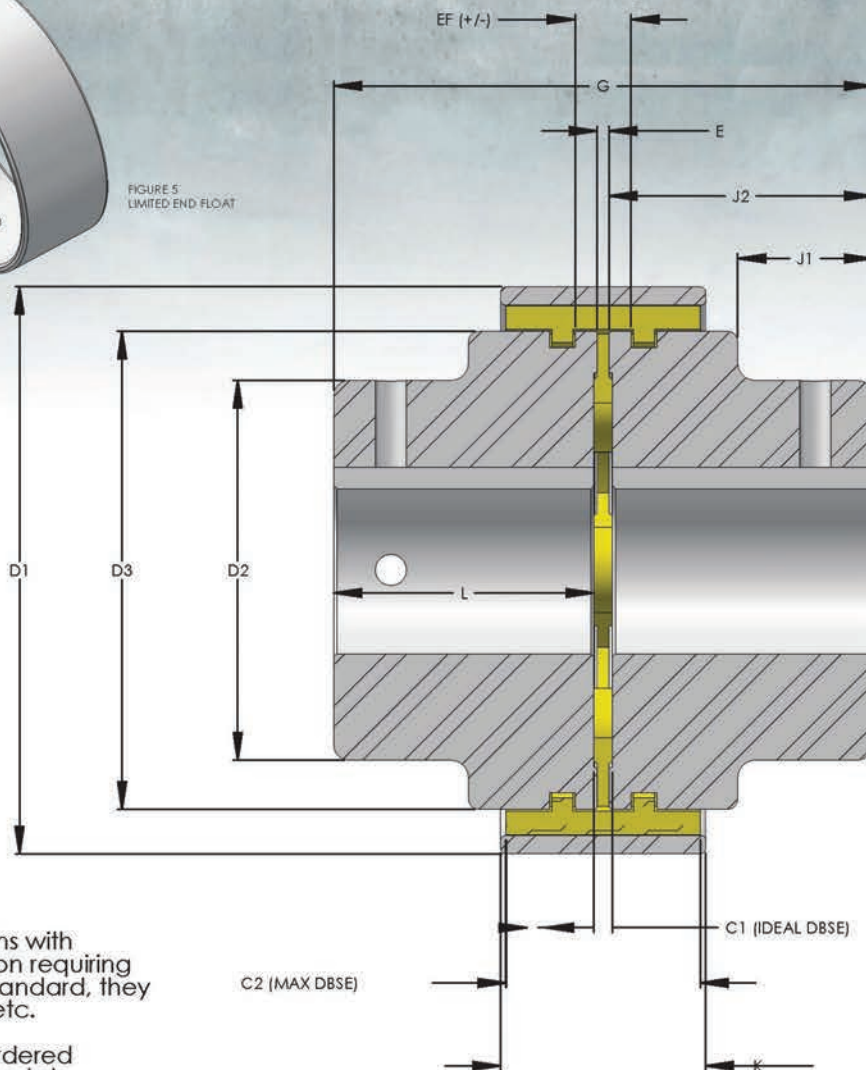

FIGURE 5  
 LIMITED END FLOAT



**\*Available in A-Series**  
**Consult factory for sizes**

Use Limited End Float Hubs and Inserts for applications with Sleeve Bearing Motors, ID & FD fans or any application requiring Limited Axial End Float. All Other components are standard, they can be used in Non-Spacer, Spacer, and Flywheel, etc.

Note: Limited End Float Couplings can be special ordered for End Float +/- increase or decrease and accommodate greater angular misalignment.

**DIMENSIONS - ATRA-FLEX® LEF SERIES**

SIZE	M1	M1H	M2	M3	M4	M5	M6	M7	M8	M9	M10	M11	M12	M13
EXTERNAL D1	3.860	4.345	4.820	5.750	7.600	9.700	11.800	13.600	15.460	17.860	19.875	23.030	27.600	34.620
TOTAL LENGTH GI	3.575	3.950	4.575	5.075	6.700	9.200	11.200	12.200	14.700	18.200	20.200	22.250	23.250	22.300
MAXIMUM BORE d1	1.750	1.9375	2.250	2.500	3.375	4.500	5.500	6.000	7.250	9.000	10.000	11.000	13.250	16.000
PILOT BORE	.500	.609	.609	.750	.940	1.000	1.500	1.750	2.450	2.900	3.750	4.000	4.000	7.000
L	1.700	1.888	2.200	2.450	3.200	4.440	5.440	5.940	7.190	8.940	9.940	10.940	11.450	10.900
D2	2.875	3.100	3.500	4.000	5.500	6.500	8.000	9.000	10.500	12.000	14.000	15.000	18.500	24.000
D3	3.150	3.470	3.900	4.900	6.400	8.150	9.930	11.900	13.940	15.900	17.900	19.650	23.900	30.000
J1	.850	1.038	1.250	1.125	1.350	2.300	3.000	2.500	2.750	4.375	5.500	5.250	5.500	3.000
J2	1.750	1.938	2.250	2.500	3.250	4.500	5.500	6.000	7.250	9.000	10.000	11.000	11.500	11.000
K	1.570	1.575	1.600	2.150	3.100	3.500	3.900	5.180	6.280	6.530	6.650	7.700	9.200	12.340
E	.075	.075	.075	.075	.200	.200	.200	.200	.200	.200	.250	.250	.250	.300
AXIAL END FLOAT +/-	+/--.025			+/--.040	+/--.070	+/--.100	+/--.100	+/--.100	+/--.060	+/--.100			+/--.100	
APPROX WT (LBS)	4	5	10	19	36	72	125	190	320	475	964	1050	1200	1500



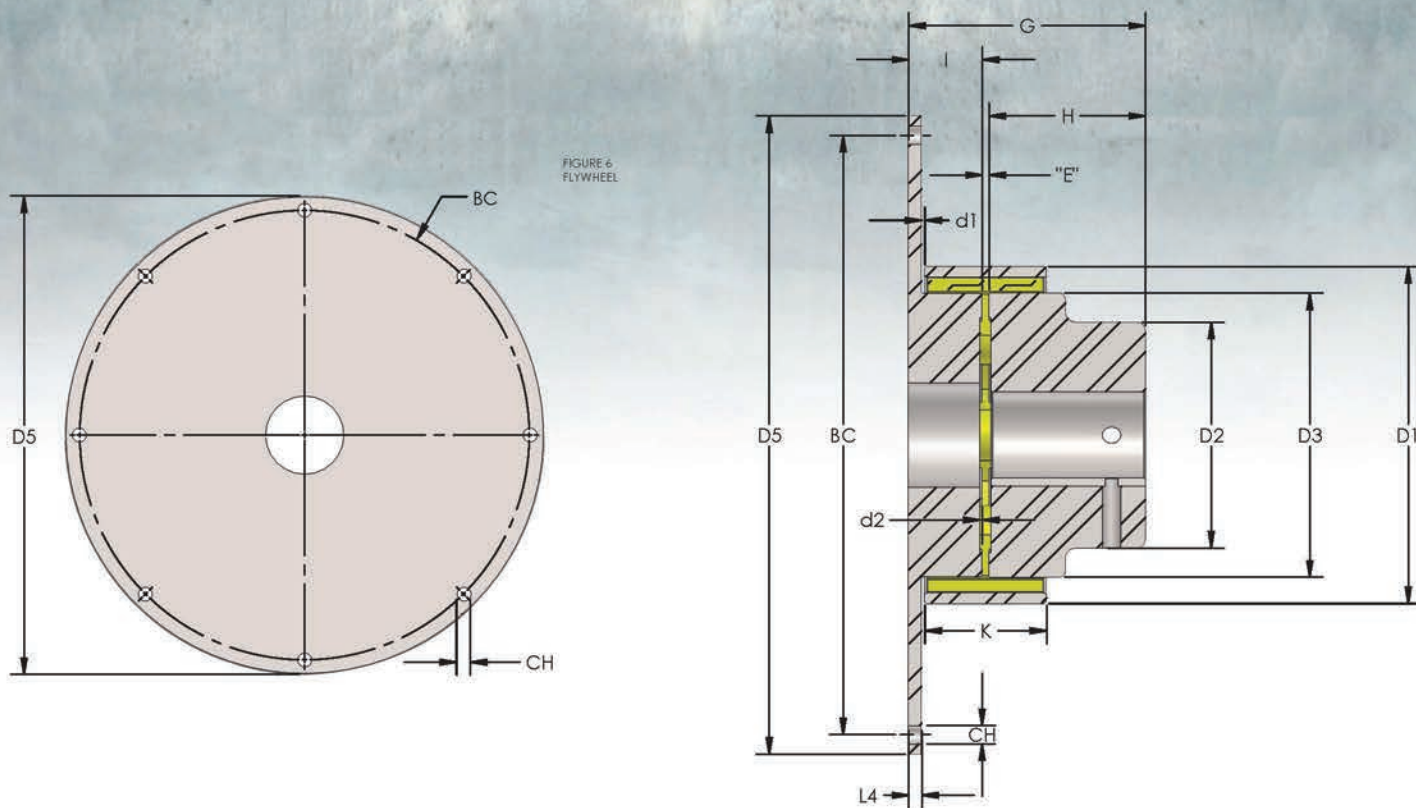

SAE FLYWHEEL COUPLING DIMENSIONS (IN INCHES) FOR Millennium

SIZE	D1	D2	D3	d1	d2	E	L4	G	H	I	MAX BORE	MAX RPM W/O BALANCING
M4	7.600	5.500	6.400	0.500	0.050	0.200	0.375	5.725	3.250	2.275	3.375	3000
M5	9.700	6.500	8.180	0.090	0.060	0.200	0.375	6.815	4.500	2.115	4.500	2500
M6	11.800	8.000	9.930	0.600	.060	0.200	0.625	8.875	5.550	3.125	5.500	2100
M7	13.260	9.000	11.900	1.000	0.060	0.200	0.750	10.450	6.000	4.250	6.000	1800
M8	15.460	10.500	13.900	1.500	0.060	0.200	0.750	12.700	7.250	5.250	7.250	1500
M9	17.860	12.000	15.900	1.500	0.060	0.200	1.000	14.825	9.000	5.625	9.000	1300
M10	19.875	14.000	17.900	1.250	0.060	0.200	1.250	16.000	10.000	5.750	10.000	1000
M12	27.600	18.500	23.900	1.500	0.060	0.250	1.250	20.750	13.250	7.250	13.250	900

FLYWHEEL DIMENSIONS FOR STANDARD CLUTCH DIAMETERS

SAE	6.5	7.5	8	10	11.5	14	16	18	21	24
D5	8.500	9.500	10.375	12.375	13.875	18.375	20.375	22.500	26.500	28.875
BC	7.875	8.750	9.625	11.625	13.125	17.250	19.250	21.375	25.250	27.250
L4	.3125	.3125	.375	.375	.375	.625	.625	.750	.750	.750
CH	.3281	.3281	.3906	.3906	.3906	.5156	.5156	.6406	.6406	.7656
CHX	6	8	6	8	8	8	8	6	12	12

\*Factory recommends a service factor of 3.0 to 4.0

\*\*Refer to horsepower capacity at various RPM on page 4 for Millennium®

\*\*\*Consult factory for custom sizes



**CONVERT YOUR GREASE LUBRICATED GRID SPACER COUPLING WITH  
THE ADVANTAGE OF NON-LUBRICATED LOW MAINTENANCE ATRA-FLEX**

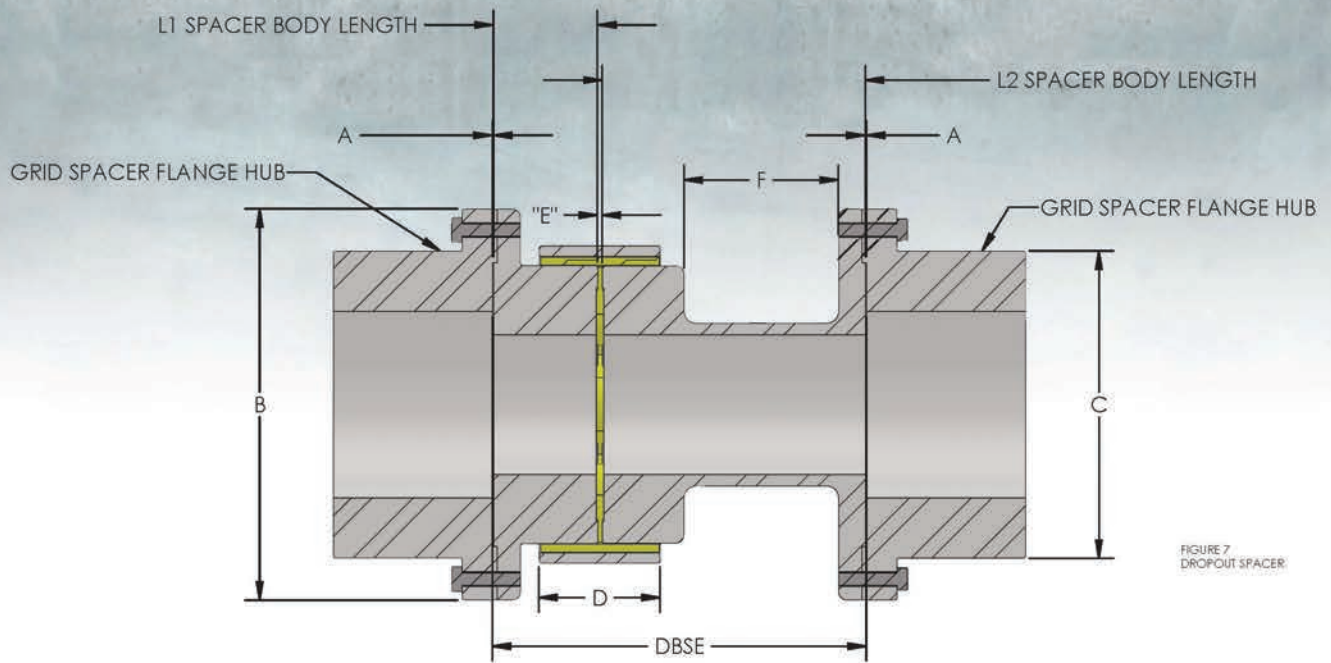

FIGURE 7  
DROPOUT SPACER

**DIMENSIONS GRID DROP-OUT CONVERSION CHART**

GRID SIZE	SIZE ATRA-FLEX	ANSI STD DBSE	A	B	C	D (RING WIDTH)	F	"E"	L1	DBSE/ =L2	G (BC)
1020 T31	20SB0MF	3.5 4.380 5.00	.050	3.300	2.060	1.145	1.700 2.580 3.200	.075	0.900	3.500 = 2.600 4.380 = 3.480 5.000 = 4.100	2.835
1030 T31	30SB1MF	3.5 4.380 5.00 7.250	.050	3.618	2.340	1.57	0.900 1.780 2.400 4.650	.075	1.300	3.500 = 2.200 4.380 = 3.080 5.000 = 3.700 7.250 = 5.950	3.110
1040 T31	40SB2MF	3.5 4.380 5.00 7.250	.050	4.375	3.090	1.600	0.700 1.580 2.200 4.450	.075	1.400	3.500 = 2.100 4.380 = 2.980 5.000 = 3.600 7.250 = 5.850	3.898
1050 T31	50SB2MF	4.380 5.00 7.250	.050	4.875	3.440	1.600	1.580 2.200 4.450	.075	1.400	4.380 = 2.980 5.000 = 3.600 7.250 = 5.850	3.898
1060 T31	60SB3MF	5.00 7.250 9.750 12.250	.050	5.690	4.060	2.050	1.05 3.300 5.800 10.275	.075	1.975	5.000 = 3.025 7.250 = 5.275 9.750 = 7.775 12.250 = 10.275	4.900
1070 T31	70SB4MF	5.00 7.250 9.750 12.250	.050	.000	4.310	3.100	0.900 3.150 5.050 8.150	.200	2.1	5.000 = 2.800 7.250 = 5.050 9.750 = 7.550 12.250 = 10.050	5.275
1080 T31	80SB5MF	7.250 9.750 12.250	.050	7.000	4.800	3.500	1.350 3.850 6.350	.200	3.075	7.250 = 4.175 9.750 = 6.675 12.250 = 9.175	6.000
1090 T31	90SB5MF	7.250 9.750 12.250	.050	8.250	5.620	3.500	1.350 3.850 6.351	.200	3.075	7.250 = 4.175 9.750 = 6.675 12.250 = 9.175	6.000

\*\* Refer to horsepower capacity at various RPM on page 4 and page 18  
\*\*\* Consult factory for larger sizes



**FLOATING SHAFT COUPLINGS  
FOR CONNECTING EQUIPMENT WITH LARGE  
DISTANCE BETWEEN SHAFT ENDS**

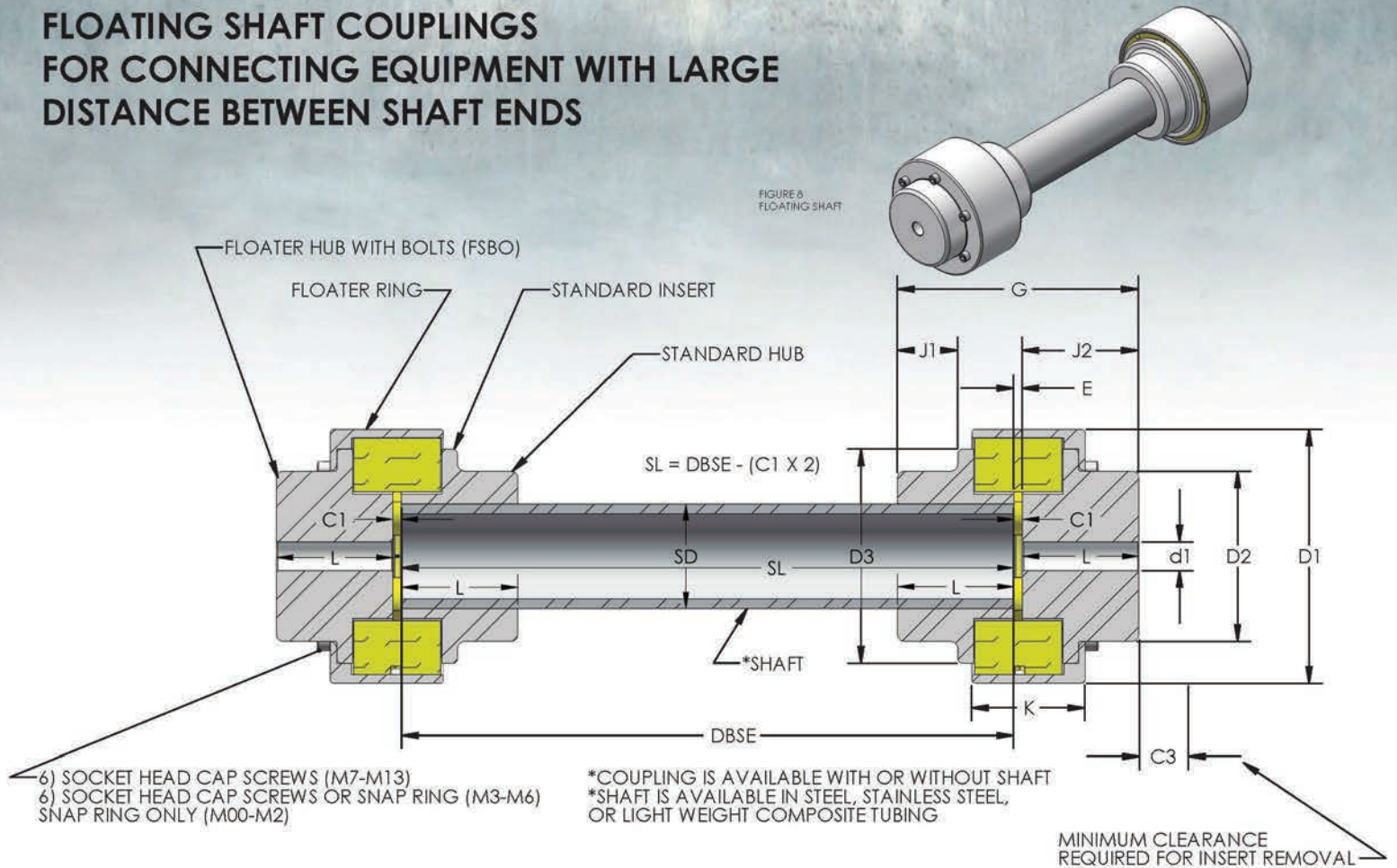

**DIMENSIONS - Millennium® FLOATING SHAFT**

SIZE	M00	M0	M1	M1H	M2	M3	M4	M5	M6	M7	M8	M9	M10	M11	M12	M13
EXTERNAL D1	2.125	2.840	3.875	4.250	4.700	5.930	7.600	9.700	11.800	13.680	15.850	17.860	19.875	23.030	27.600	34.620
G	2.050	2.825	3.575	3.950	4.575	5.075	6.700	9.200	11.200	12.200	14.700	18.200	20.200	22.250	23.250	22.300
MAXIMUM BORE	1.000	1.375	1.750	1.9375	2.250	2.500	3.375	4.500	5.500	6.000	7.250	9.000	10.000	11.000	13.250	16.000
PILOT BORE d1	0.250	0.300	0.500	0.609	0.609	0.750	0.940	1.100	1.500	1.750	2.450	2.900	3.750	4.000	4.000	7.000
C1	0.132	0.145	0.195	.195	0.195	0.195	0.320	0.320	0.320	0.320	0.320	0.320	0.370	0.370	0.370	0.420
C3	0.185	0.450	0.820	0.625	1.250	1.250	1.930	1.430	1.460	3.180	4.250	2.625	1.430	2.485	4.475	8.900
L	0.935	1.340	1.690	1.875	2.440	2.440	3.190	4.440	5.440	5.940	7.190	8.940	9.940	10.940	11.440	10.900
D2	1.600	2.200	2.875	3.100	4.000	4.000	5.500	6.500	8.000	9.000	10.500	12.000	14.000	15.000	18.500	24.000
D3	1.700	2.400	3.150	3.470	4.900	4.900	6.400	8.180	9.930	11.900	13.940	15.900	17.900	19.650	23.900	30.000
J1	0.600	0.775	0.850	1.038	1.125	1.125	1.350	2.300	3.000	2.500	2.750	4.375	5.500	5.750	5.500	3.000
J2	1.000	1.375	1.750	1.938	2.500	2.500	3.250	4.500	5.500	6.000	7.250	9.000	10.000	11.000	11.500	11.000
K	.900	1.325	1.870	1.860	2.750	2.750	3.780	4.330	5.060	6.680	8.250	8.500	8.180	9.735	11.475	14.150
*SD (SHAFT DIAMETER)	1.000	1.250	1.500	1.500	2.000	2.000	3.000	4.000	5.000	5.500	7.000	8.500	9.500	10.500	13.000	15.500
E (GAP)	0.62	.075	.075	.075	.075	.075	.200	.200	.200	.200	.200	.200	.250	.250	.250	.300

\*Shaft Dimensions subject to change without notice.  
Refer to Horsepower Capacity at various RPM on pages 4 & 18



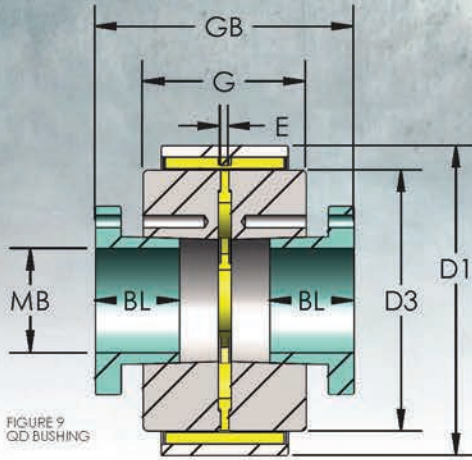

FIGURE 9  
QD BUSHING

**QD BUSHING**

SIZE	QD	MB	GB	G	D1	D3	E	BL
M0	JA	1.250	2.311	1.451	2.840	2.400	.075	1.062
M1	SH	1.6875	3.025	1.925	3.860	3.150	.075	1.312
M1H	SH	1.6875	3.025	1.925	4.345	3.470	.075	1.312
M2	SDS	2.000	3.025	1.925	4.820	3.900	.075	1.312
M3	SK	2.500	6.485	4.925	5.750	4.900	.075	1.937
M4	SF	2.9875	5.700	4.000	7.600	6.400	.200	2.062
M5	F	4.000	8.624	5.945	9.700	8.150	.200	3.750
M6	J	4.500	10.320	7.320	11.800	9.930	.200	4.630
M7	M	5.500	19.810	16.490	13.250	11.900	.200	6.750
M8	N	6.000	24.070	19.950	15.460	13.940	.200	8.125
M9	P	7.000			17.860	15.900	.200	9.375
M10	W	8.000	28.950	23.950	19.875	17.900	.200	11.370
M11	W	8.000			23.030	19.650	.200	11.370
M12	S	10.000			27.600	23.900	.250	15.250

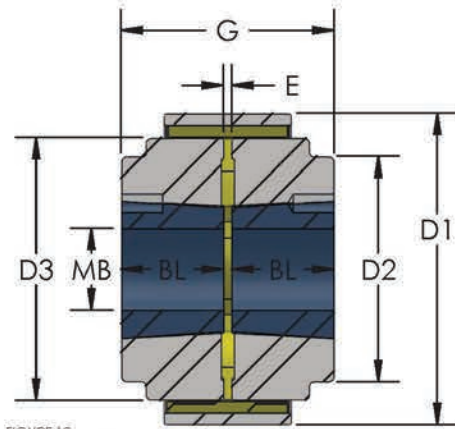

FIGURE 10  
EXTERNAL TAPER-LOCK

**TAPER-LOCK BUSHING EXTERNAL**

SIZE	TL EXT	MB	G	D1	D3	E	BL
M0	1008	.5625		2.840	2.400	.075	.875
M1	1108	1.125	1.975	3.860	3.150	.075	.875
M1H	1215	1.250	3.200	4.345	3.470	.075	1.500
M2	1615	1.6875	3.175	4.820	3.900	.075	1.500
M3	2012	2.125	4.075	5.750	4.900	.075	1.250
M4	2525	2.500	5.300	7.600	6.400	.200	2.500
M5	3020	3.000	4.600	9.700	8.150	.200	2.000
M6	4040	4.4375	8.320	11.800	9.930	.200	4.000
M7	5050	5.000	15.700	13.250	11.900	.200	5.000
M8	6050	6.000	17.450	15.460	13.940	.200	5.000
M9	7060	7.000		17.860	15.900	.200	6.000
M10	8065	8.000		19.875	17.900	.200	6.500
M11	8065	8.000		23.030	19.650	.200	6.500
M12	10085	10.000		27.600	23.900	.250	8.500

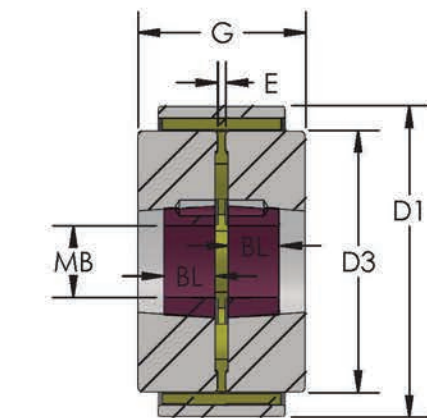

FIGURE 11  
INTERNAL TAPER-LOCK

**TAPER-LOCK BUSHING INTERNAL**

SIZE	TL INT	MB	G	D1	D3	E	BL
M0	N/A	N/A	N/A	N/A	N/A	N/A	N/A
M1	1108	1.125		3.860	3.150	.075	.875
M1H	1215	1.250		4.345	3.470	.075	1.500
M2	1310	1.375	2.325	4.820	3.900	.075	1.000
M3	1610	1.625	2.575	5.750	4.900	.075	1.000
M4	2012	2.125	4.100	7.600	6.400	.200	1.250
M5	3020	3.000	4.600	9.700	8.150	.200	2.000
M6	3535	3.500	7.570	11.800	9.930	.200	3.500
M7	4040	4.4375	8.320	13.250	11.900	.200	4.000
M8	4545	4.500		15.460	13.940	.200	4.500
M9	5050	5.000		17.860	15.900	.200	5.000
M10	6050	6.000		19.875	17.900	.200	5.000
M11	6050	6.000		23.030	19.650	.200	5.000
M12	8065	8.000		27.600	23.900	.250	6.500



Application Range: Coupling sizes available to transmit torque loads from 60 in/lbs to over 1.57 million in/lbs with shaft capacities ranging from .375 to over 20.00 running from low rpm to over 18,000 rpm.

Coupling Types: Close coupled, Spacer types, Limited End Float, Slide, Floating Shaft, Flywheel, Brake Wheel, Brake Disc, and made to order engineered couplings.

How it works: T-Flex close coupled couplings consist of four parts. The Ring Hub (1), Flex Hub (2), Insert (3), and Drive Ring (4). The Ring Hub and Flex Hub are installed on the shafts with the Drive Ring fitting over the Flex Hub. After coupling alignment, the Insert is placed around the Flex Hub engaging the bottom lobes of the Insert. The Drive Ring is then fitted over the Insert engaging the top lobes of the Insert. The Drive Ring is then fastened to the Ring Hub using high strength alloy steel socket head cap screws with high collar lock washers. The coupling will now transmit torque with silent, smooth reliable, maintenance free operation.

Manufacturing: T-Flex is manufactured in the USA. Standard hubs and rings are machined from solid carbon steel rounds and tubing, maintaining tight tolerances which provides excellent coupling balance. Stainless steels in grades 303, 304, and 316 are also available for corrosive environments and food applications. We also offer a low cost, alternative to stainless steel called Melonite Process which turns carbon steel black and prevents wear and corrosion. TFlex® inserts are made from durable custom compounded polyurethane that offer resistance to almost every fluid found in industry today. Using TFlex® ensures dependable, maintenance free torque transmission for your rotational equipment, and comes with product / technical support from our knowledgeable staff with over 25 years experience.

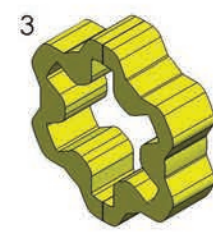
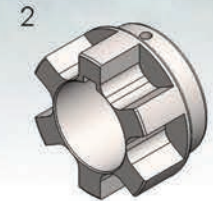
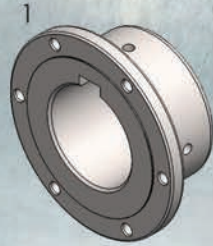

- Patented T-Flex® absorbs extreme torsional shock and vibration while accommodating angular, parallel, and axial misalignment without generating reactionary loads, which significantly increases bearing life.
- T-Flex® uniquely combines the stability of a compression type coupling with the safety of a shear coupling. In the event of a lockup, the insert will shear, minimizing the possibility of damaging your rotational equipment.
- No lubrication or routine maintenance is required.
- The rugged polyurethane insert is the only spare part and can be replaced in minutes without having to move the equipment or the shaft hubs.
- Standard inserts have a temperature range from -60° to 250° Fahrenheit with high temperature inserts available up to 350°.
- The inserts are available in a range of hardness to meet most torsional stiffness and torque requirements, and offers very high resistance to chemicals and weather.
- T-Flex® couplings are suitable for blind assembly, horizontal or vertical, reversing, and stop/start applications.
- The Compact size to torque ratio with generous bore capacity allows proper sizing.
- Hubs are available for use with tapered bushings, lock assemblies, shrink discs, finished bored and keyed, taper bored, and spline bored.
- Melonite Process available for enhanced corrosion and wear resistance. Low cost alternative to stainless steel.

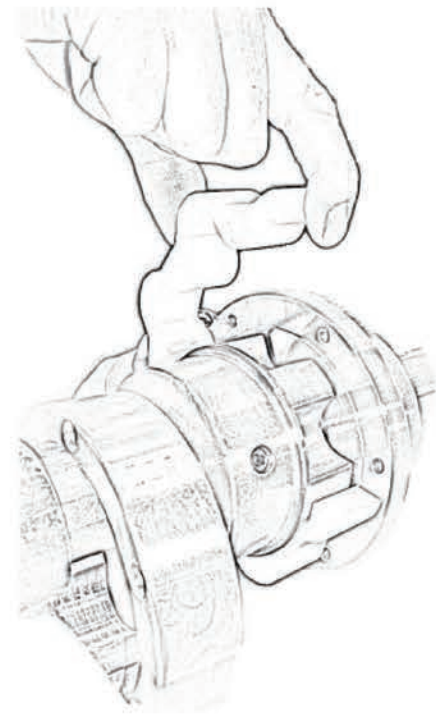
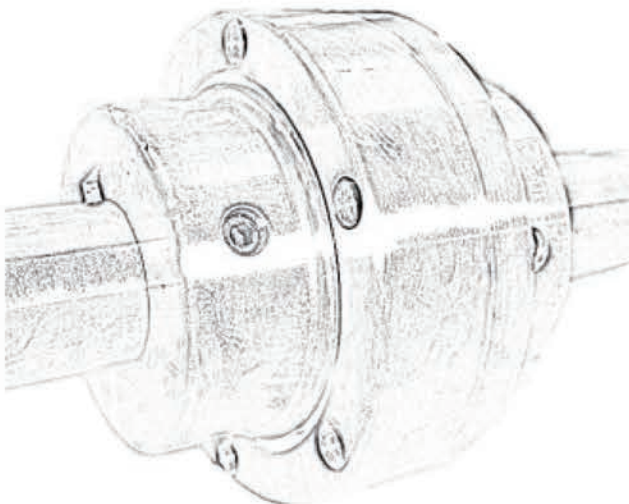



- 1) Determine service factor (SF)  
 $SF = F1 \times F2$  (not to exceed 4)

DRIVER F1	SF
ELECTRIC MOTOR	1.0
GAS OR STEAM TURBINE	1.0
GEAR BOX INCREASER / REDUCER	1.0
GAS OR DIESEL ENGINE 4+ CYL	3.0
GAS OR DIESEL ENGINE 1-3 CYL	4.0

- 2) Calculate required coupling continuous torque rating (lb-in) using the formula:  $HP \times SF \times 63025 \div RPM = \text{Torque (lb-in)}$

DRIVEN F2	SF
GENERATORS, GEAR BOXES, LIGHT DUTY AGITATORS & CONVEYERS, STOKERS	1.0
CENTRIFUGAL PUMPS, COMPRESSORS, BLOWERS, FANS, ETC.	1.0
RECIPROCATING PUMPS, COMPRESSORS, FEEDERS, FREQUENT STOPS/STARTS, ETC.	2.0
PULP & PAPER MILL EQUIPMENT (REFER TO MILL STANDARD COUPLING SF GUIDE)	1-3
STEEL MILL EQUIPMENT (REFER TO MILL STANDARD COUPLING SF GUIDE)	1-3

- 3) Determine suitable coupling insert type for application using the Insert Color Chart below:

INSERT TYPE	DESCRIPTION	USE	MAX TEMP °F	MIN TEMP °F	DIUROMETER
YELLOW	GENERAL USE, HIGH DAMPEN	GENERAL APPLICATIONS (STANDARD)	250	-60	60D
RED	HIGH TEMPERATURE, HIGH DAMPEN	HIGH TEMPERATURE RUNNING APPLICATIONS	350	20	90A
ORANGE	HIGH TORQUE, MEDIUM DAMPEN	HIGH TORQUE, LOW SPEED APPLICATIONS	250	-20	70D
GREEN	EXTRA HIGH DAMPENING	ENGINE OR RECIPROCATING WITH HIGH VIBRATORY TORQUES	250	-20	90A

- 4) Choose the coupling size that meets or exceeds the calculated required continuous torque rating using the color coded tables below. Intermittent (peak) ratings are reserved for system torque spikes, starts/stops, reversing etc.

Insert Tables: Torque ratings (lb-in) - HP ratings @ various RPMs - Max RPM's based on insert types:

INSERT YELLOW	T-0	T-1	T-2	T-3	T-4	T-5	T-6	T-7	T-8	T-9	T-10	T-11	T-12
CONTINUOUS (LB-IN)	1000	1600	3800	6000	12000	35000	64700	120000	202000	304000	540000	720000	950000
INTERMITTENT (LB-IN)	1800	2500	7000	9600	19200	60000	103600	200000	269600	500000	860000	1050000	1380000
HP @ 100 RPM (SF1)	1.59 2.86	2.54 3.97	6.03 11.11	9.52 15.23	19.04 30.46	56 95	103 164	190 317	321 428	482 793	857 1365	1142 1666	1507 2190
HP @ 1200 RPM (SF1)	19.04 34.27	30.46 48	72.35 133	114 183	228 366	666 1142	1232 1973	2285 3808	3850 5133	5788 9520	10282 16374	13709 19992	18088 26275
HP @ 1750 RPM (SF1)	27.77 49.98	44 69	106 194	167 267	333 533	972 1666	1795 2877	3332 5553	5614 7486	8441 13883	14994 23879	19992 29155	26378 38318
HP @ 3600 RPM (SF1)	57.12 103	91 143	217 400	343 548	685 1095	1999 3427	3696 5918	6854 11424					
MAX RPM UNBALANCED	12000	10000	8000	6000	4500	3600	2800	2300	1750	1450	1300	1200	1000
MAX RPM BALANCED G2.5	18000	16000	14000	12000	10500	8500	5500	3600	2400	2100	1750	1750	1400

INSERT RED	T-0	T-1	T-2	T-3	T-4	T-5	T-6	T-7	T-8	T-9	T-10	T-11	T-12
CONTINUOUS (LB-IN)	850	1360	3230	5100	10200	29750	54995	102000	171700	258400	459000	612000	807500
INTERMITTENT (LB-IN)	1530	2125	5950	8160	16320	51000	86060	170000	229160	425000	731000	892500	1173000
HP @ 100 RPM (SF1)	1.35 2.43	2.16 3.37	5.13 9.44	8.09 12.95	16.18 25.89	48 81	88 139	162 269	273 364	410 674	728 1160	971 1416	1281 1862
HP @ 1200 RPM (SF1)	16.18 29.13	25.89 41	61.50 113	97 156	194 311	566 971	1047 1677	1942 3237	3273 4363	4920 8092	8740 13918	11653 16993	15375 22334
HP @ 1750 RPM (SF1)	23.60 42.48	37 59	90 165	142 227	283 453	826 1416	1526 2445	2832 4720	4772 6363	7175 11801	12745 20297	16993 24782	22421 32570
HP @ 3600 RPM (SF1)	48.55 88	77 122	184 340	292 456	582 931	1699 2913	3142 5030	5826 9710					
MAX RPM UNBALANCED	12000	10000	8000	6000	4500	3600	2800	2300	1750	1450	1300	1200	1000
MAX RPM BALANCED G2.5	18000	16000	14000	12000	10500	8500	5500	3600	2400	2100	1750	1750	1400

INSERT ORANGE	T-0	T-1	T-2	T-3	T-4	T-5	T-6	T-7	T-8	T-9	T-10	T-11	T-12
CONTINUOUS (LB-IN)	1130	3000	6000	9000	18600	60000	106800	200000	333600	452000	890000	1100000	1570000
INTERMITTENT (LB-IN)	2260	4000	9000	12600	24000	80000	170900	300000	444900	603000	1400000	1650000	2280000
HP @ 100 RPM (SF1)	1.79 3.59	4.76 6.35	9.52 14.28	14.28 19.99	24.75 38.08	95 127	169 271	335 557	529 706	717 957	1412 2221	1745 2618	2491 3618
HP @ 1200 RPM (SF1)	21.52 43.03	57.12 76	114 171	171 240	297 457	1142 1523	2033 3254	4017 6683	6352 8471	8606 11481	16946 26656	20944 31416	29893 43411
HP @ 1750 RPM (SF1)	31.38 62.75	83 111	167 250	250 350	433 666	1666 2221	2965 4745	5859 9746	9263 12353	12551 16743	24712 38873	30543 45815	43594 63308
HP @ 3600 RPM (SF1)	64.55 130	171 228	343 514	514 720	891 1371	3427 4570	6100 9762	12052 20049					
MAX RPM UNBALANCED	12000	10000	8000	6000	4500	3600	2800	2300	1750	1450	1300	1200	1000
MAX RPM BALANCED G2.5	16000	16000	12000	10000	8000	6500	4200	3600	2400	2100	1750	1750	1400

INSERT GREEN	T-0	T-1	T-2	T-3	T-4	T-5	T-6	T-7	T-8	T-9	T-10	T-11	T-12
CONTINUOUS (LB-IN)	413	450	1598	2700	5400	14438	26689	54000	83408	125250	202500	294000	356250
INTERMITTENT (LB-IN)	743	900	3150	4500	9000	24750	42735	75000	111210	206250	322500	412500	517500
HP @ 100 RPM (SF1)	0.65 1.18	0.71 1.43	2.54 5.00	4.28 7.14	8.57 14.28	23 39	42 68	86 119	132 176	199 327	321 512	467 655	566 821
HP @ 1200 RPM (SF1)	7.85 14.14	8.57 17	30.42 59.98	51.75 85.50	103 171	275 471	509 814	1028 1428	1588 2117	2385 3927	3856 6140	5598 7854	6783 9854
HP @ 1750 RPM (SF1)	11.45 20.62	13 25	44 88	75 125	150 250	401 687	741 1187	1499 2083	2316 3088	3478 5727	5623 8955	8164 11454	9892 14369
HP @ 3600 RPM (SF1)	24 42	26 52	92 180	155 257	308 514	825 1414	1525 2441	3085 4284					
MAX RPM UNBALANCED	12000	10000	8000	6000	4500	3600	2800	2300	1750	1450	1300	1200	1000
MAX RPM BALANCED G2.5	18000	16000	14000	12000	10500	8500	5500	3600	2400	2100	1750	1750	1400

- 5) Determine coupling type required for the application. Check dimensions/max bore tables to confirm the coupling sized will accommodate shafts and physically fit the application. Determine if the couplings hubs will be bored to size, or used with Taper Lock Bushings, QD Bushings, or other type of locking device. Standard couplings are machined carbon steel. Specify if stainless steel or Melonite Process is required based on atmosphere conditions, etc.

Listed service factors are intended as a general guide, and are typical of usual service requirements. Please refer to AGMA 922-A96: Load Classification and Service Factors for Flexible Couplings for a complete list.



FIGURE 12  
NON-SPACER

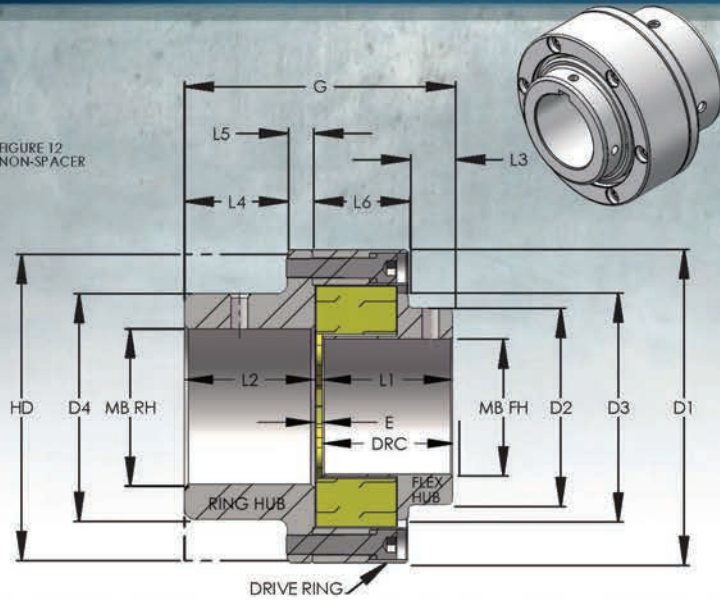
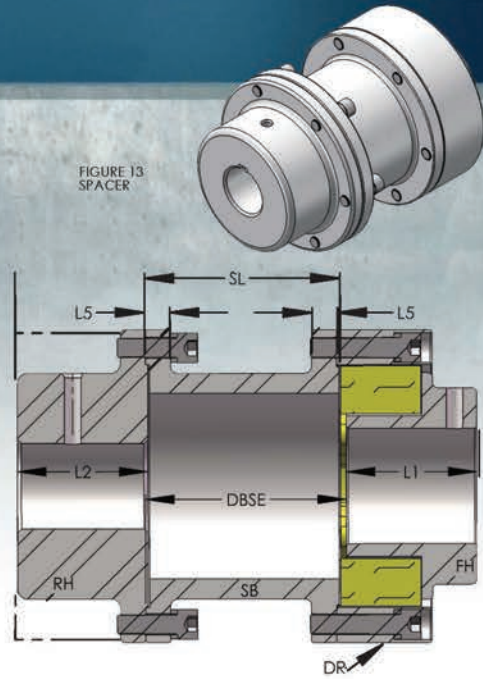

FIGURE 13  
SPACER



Non-spacer couplings are easily converted to spacer couplings simply by adding the spacer body. All other components are standard. Spacer Length (SL) = DBSE - E to allow proper gap. See Table 2 for standard stocked spacer lengths.

SIZE>	T-0	T-1	T-2	T-3	T-4	T-5	T-6	T-7	T-8	T-9	T-10	T-11	T-12
G	2.850	3.600	4.600	5.100	6.680	8.180	10.180	12.200	14.200	16.200	18.200	20.250	22.275
D1	2.950	3.960	4.800	6.290	7.800	9.765	11.900	13.600	14.625	18.020	19.950	23.250	28.500
MBFH	1.375	1.750	2.250	2.500	3.375	4.500	5.500	6.250	7.125	9.000	10.000	11.250	12.875
MBRH	1.625	2.250	2.500	3.375	3.875	5.250	6.250	7.250	7.625	10.375	12.000	12.500	15.000
MBHD	1.875	2.750	2.875	4.500	5.250	6.625	8.250	9.250	10.625	13.250	15.375	17.500	20.000
RSB	.300	.500	.600	.750	.950	1.000	1.500	1.750	2.250	2.900	3.700	3.900	3.900
E	.100	.100	.100	.100	.180	.180	.180	.200	.200	.200	.200	.250	.275
D2	1.995	2.585	3.200	4.000	4.900	6.500	7.875	9.250	10.167	12.775	14.625	16.000	18.500
D3	2.050	2.820	3.500	4.500	5.650	7.350	8.515	10.065	10.435	13.780	15.710	17.875	20.988
D4	2.470	3.200	3.625	5.000	5.625	7.500	8.875	10.750	11.375	13.875	16.500	17.500	22.875
HD	2.850	3.840	4.650	6.125	7.500	9.500	11.375	13.250	14.375	17.670	19.700	23.000	27.000
L1	1.375	1.750	2.250	2.500	3.250	4.000	5.000	6.000	7.000	8.000	9.000	10.000	11.000
L2	1.375	1.750	2.250	2.500	3.250	4.000	5.000	6.000	7.000	8.000	9.000	10.000	11.000
L3	.650	.705	1.200	1.125	1.115	1.325	2.475	2.485	3.250	3.875	4.140	4.250	4.900
L4	.980	1.295	1.730	1.825	2.565	3.065	3.940	4.925	5.690	6.440	6.875	7.900	8.440
L5	.375	.4375	.500	.625	.625	.875	1.000	1.125	1.250	1.500	2.000	2.000	2.500
L6	.835	1.165	1.165	1.500	2.375	2.875	2.715	3.795	3.900	4.385	5.185	6.100	6.375
DRC	1.450	2.085	2.500	2.700	4.250	5.175	4.865	6.815	7.140	8.010	9.570	11.100	11.675
S1	1.000	1.350	1.438	1.815	2.575	3.125	3.250	4.250	4.500	5.125	6.000	7.000	7.250
S2	.6875	.875	1.125	1.250	1.625	2.000	2.500	3.000	3.500	4.000	4.500	5.000	5.500
SS	5/16	5/16	3/8	3/8	1/2	5/8	3/4	1-8	1-8	1-8	1-8	1-8	1-8
LBS	5	10	15	25	50	105	180	285	365	600	950	1250	1750

Note: Size T-6 thru T-12 spacers are made to order. Special inventory arrangements can be made with the end user if needed. Consult Factory for Min/Max spacer lengths

SIZE	3.0	3.5	3.75	4.0	5.0	5.5	6.0	7.0	7.5	9.0	9.5	9.75	10.0	12.0
T-0	X	X	X											
T-1	X	X	X	X										
T-2	X	X	X	X	X	X	X	X	X					
T-3	X	X	X	X	X	X		X	X					
T-4		X	X	X	X	X	X	X	X	X	X	X	X	
T-5					X		X	X	X	X	X	X	X	X

FIGURE 15  
HEAVY DUTY RING HUB

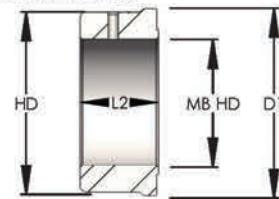

MB HD: Use the Heavy Duty Ring Hub for shafts larger than MB RH. RH HD must be specified when ordering RSB for the larger shafts. Available for use with Spacer and Non-spacer Couplings

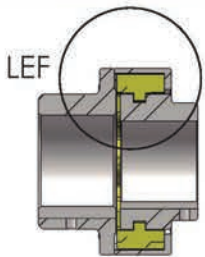
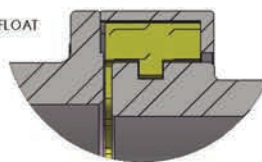

FIGURE 14  
LIMITED END FLOAT



Note: T-Flex standard couplings are designed to allow free axial movement of driver and driven shafts. Limited End Float couplings should be specified for all applications requiring limited or controlled axial end float such as Sleeve/Babbit bearing motors, fans, blowers, etc. Consult factory for questionable applications. Limited End Float Flex Hub and Inserts are used with standard Ring Hubs and Drive Rings. Available for use with Spacer and Non-spacer Couplings.

ATR Sales Inc. reserves the right to change design without notice. The dimensions and weights listed are approximate and sufficient for most users. Dimensions L3 and L4 may be faced off as needed for length restrictions. (see page 12 for shaft contact) The purchaser should request certified prints for couplings requiring tighter tolerances, critical dimensions and/or weights. Contact ATR Sales @ 800-443-6613



# LIMITED END FLOAT DIMENSIONS / TOLERANCES

Patent #7,244,186

**ATRA-FLEX®**  
T-FLEX®

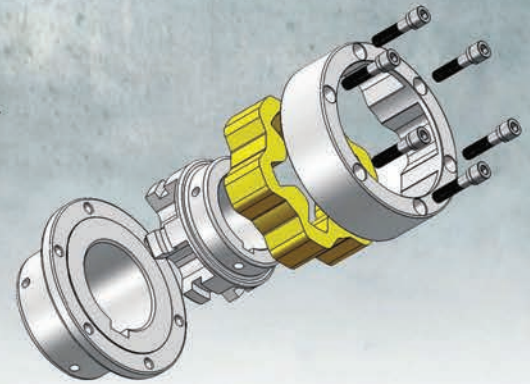
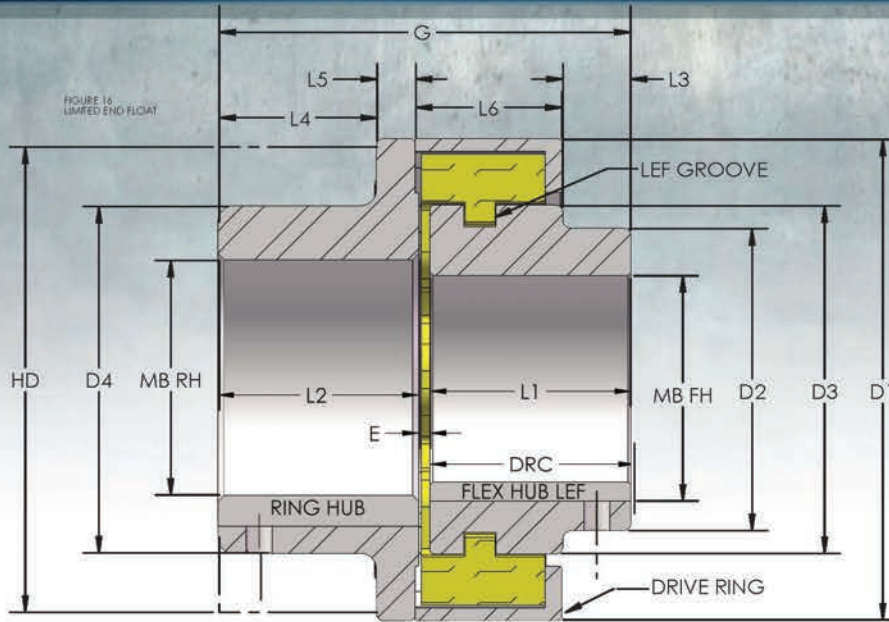

SIZE>	T-0	T-1	T-2	T-3	T-4	T-5	T-6	T-7	T-8	T-9	T-10	T-11	T-12
G	2.850	3.600	4.600	5.100	6.680	8.180	10.180	12.200	14.200	16.200	18.200	20.250	22.275
D1	2.950	3.960	4.800	6.290	7.800	9.765	11.900	13.600	14.625	18.020	19.950	23.250	28.500
MBFH	1.375	1.750	2.250	2.500	3.375	4.500	5.500	6.250	7.125	9.000	10.000	11.250	12.000
MBRH	1.625	2.250	2.500	3.375	3.875	5.250	6.250	7.250	7.625	10.375	12.000	12.500	15.000
MBHD	1.875	2.750	2.875	4.500	5.250	6.625	8.250	9.250	10.625	13.250	15.375	17.500	20.000
RSB	.300	.500	.600	.750	.950	1.000	1.500	1.750	2.250	2.900	3.700	3.900	3.900
E	.100	.100	.100	.100	.180	.180	.180	.200	.200	.200	.200	.250	.275
D2	1.995	2.585	3.200	4.000	4.900	6.500	7.875	9.250	10.167	12.775	14.625	16.000	18.500
D3	2.050	2.820	3.500	4.500	5.650	7.350	8.515	10.065	10.435	13.780	15.710	17.875	20.988
D4	2.470	3.200	3.625	5.000	5.625	7.500	8.875	10.750	11.375	13.875	16.500	17.500	22.875
HD	2.850	3.840	4.650	6.125	7.500	9.500	11.375	13.250	14.375	17.670	19.700	23.000	27.000
L1	1.375	1.750	2.250	2.500	3.250	4.000	5.000	6.000	7.000	8.000	9.000	10.000	11.000
L2	1.375	1.750	2.250	2.500	3.250	4.000	5.000	6.000	7.000	8.000	9.000	10.000	11.000
L3	.650	.705	1.200	1.125	1.115	1.325	2.475	2.485	3.250	3.875	4.140	4.900	4.900
L4	.980	1.295	1.730	1.825	2.565	3.065	3.940	4.925	5.690	6.440	6.875	7.900	8.440
L5	.375	.4375	.500	.625	.625	.875	1.000	1.125	1.250	1.500	2.000	2.000	2.500
L6	.835	1.165	1.165	1.500	2.375	2.875	2.715	3.795	3.900	4.385	5.185	6.100	6.375
DRC	1.450	2.085	2.500	2.700	4.250	5.175	4.865	6.815	7.140	8.010	9.570	11.100	11.67
S1	1.000	1.350	1.438	1.815	2.575	3.125	3.250	4.250	4.500	5.125	6.000	7.000	7.250
S2	.6875	.875	1.125	1.250	1.625	2.000	2.500	3.000	3.500	4.000	4.500	5.000	5.500
SS	5/16	5/16	3/8	3/8	1/2	5/8	3/4	1-8	1-8	1-8	1-8	1-8	1-8
LBS	5	10	15	25	50	105	180	285	365	600	95	1250	1750

Use Limited End Float Flex Hub and Inserts for applications with Sleeve Bearing Motors, ID & FD fans or any application requiring Limited Axial End Float. All Other components are standard, they can be used in Non-Spacer, Spacer, and Flywheel, etc.

Note: Limited End Float Couplings can be special ordered for End Float +/- increase or decrease and accommodate greater angular misalignment. They can also be combined with Axial Slide Couplings to be used as stops for < or > travel. Consult factory for special design needs.

SIZE T-FLEX® LEF	END FLOAT +/-	PARALLEL P (TIR)	ANGULAR A
T-1	.050 / .035	.040	1°
T-2	.050 / .035	.040	1°
T-3	.050 / .035	.040	1°
T-4	.050 / .035	.060	.5°
T-5	.050 / .035	.060	.5°
T-6	.050 / .035	.060	.5°
T-7	.050 / .035	.060	.5°
T-8	.050 / .035	.060	.5°
T-9	.050 / .035	.080	.5°
T-10	.050 / .035	.080	.5°
T-11	.050 / .035	.100	.5°
T-12	.050 / .035	.100	.5°

ATR SALES INC. reserves the right to change design without notice. The dimensions and weights listed are approximate and sufficiently accurate for most users. The purchaser should use certified prints for construction where exact dimensions and weights are critical. Additional information will be provided if extreme accuracy is required.



# AXIAL SLIDE COUPLING DIMENSIONS

Patent #7,244,186

E E+ E- SL

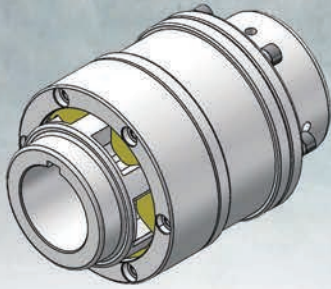

SPECIFY E + / -  
COUPLINGS ARE MADE TO ORDER

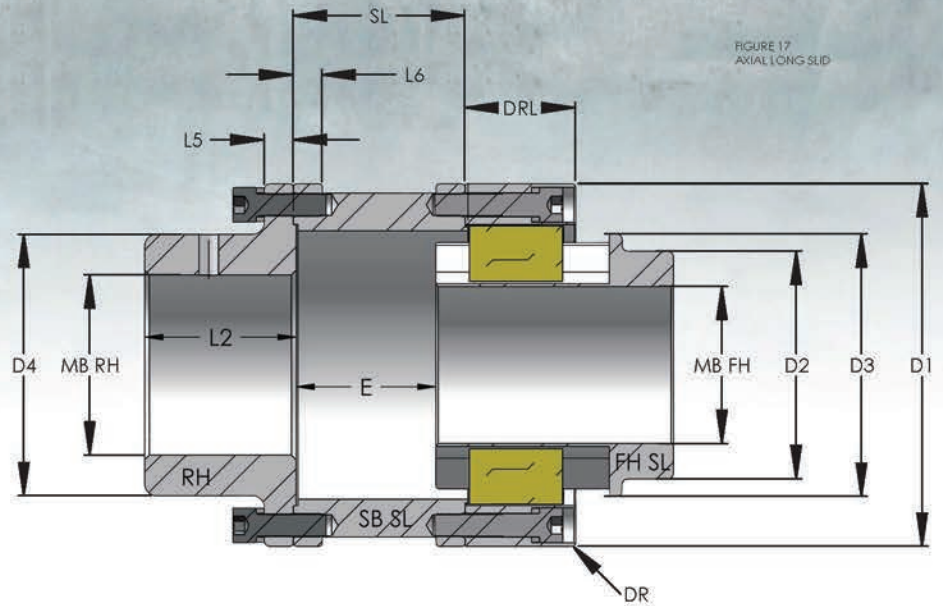
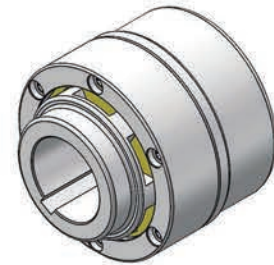
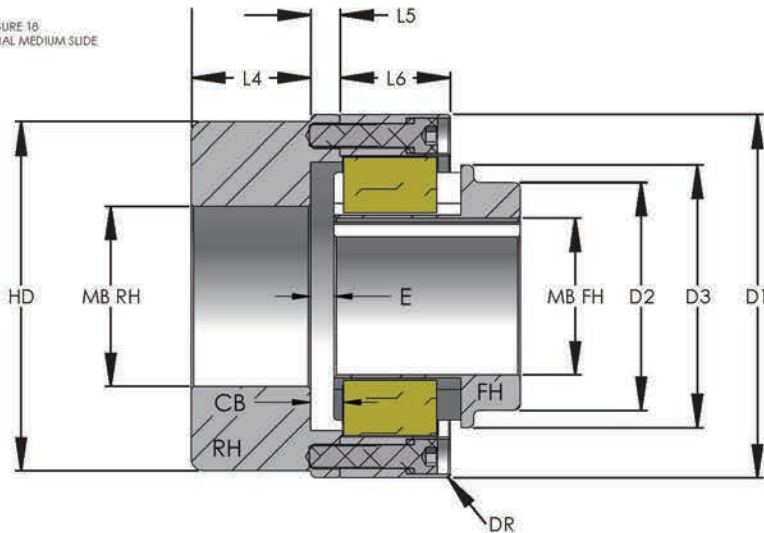

FIGURE 17  
AXIAL LONG SLID

E E+ E-

FIGURE 16  
AXIAL MEDIUM SLIDE



SIZE>	T-0	T-1	T-2	T-3	T-4	T-5	T-6	T-7	T-8	T-9	T-10	T-11	T-12
G	2.850	3.600	4.600	5.100	6.680	8.180	10.180	12.200	14.200	16.200	18.200	20.250	22.275
D1	2.950	3.960	4.800	6.290	7.800	9.765	11.900	13.600	14.625	18.020	19.950	23.250	28.500
MBFH	1.375	1.750	2.250	2.500	3.375	4.500	5.500	6.250	7.125	9.000	10.000	11.250	12.000
MBRH	1.625	2.250	2.500	3.375	3.875	5.250	6.250	7.250	7.625	10.375	12.000	12.500	15.000
MBHD	1.875	2.750	2.875	4.500	5.250	6.625	8.250	9.250	10.625	13.250	15.375	17.500	20.000
RSB	.300	.500	.600	.750	.950	1.000	1.500	1.750	2.250	2.900	3.700	3.900	3.900
D2	1.995	2.585	3.200	4.000	4.900	6.500	7.875	9.250	10.167	12.775	14.625	16.000	18.500
D3	2.050	2.820	3.500	4.500	5.650	7.350	8.515	10.065	10.435	13.780	15.710	17.875	20.988
D4	2.470	3.200	3.625	5.000	5.625	7.500	8.875	10.750	11.375	13.875	15.800	17.500	22.875
HD	2.850	3.840	4.650	6.125	7.500	9.500	11.375	13.250	14.375	17.670	19.700	23.000	27.000
L2	1.375	1.750	2.250	2.500	3.250	4.000	5.000	6.000	7.000	8.000	9.000	10.000	11.000
L3	.650	.705	1.200	1.125	1.115	1.325	2.475	2.485	3.250	3.875	4.140	4.250	4.900
L4	.980	1.295	1.730	1.825	2.565	3.065	3.940	4.925	5.690	6.440	6.875	7.900	8.440
L5	.375	.4375	.500	.625	.625	.875	1.000	1.125	1.250	1.500	2.000	2.000	2.500
L6	.835	1.165	1.165	1.500	2.375	2.875	2.715	3.795	3.900	4.385	5.185	6.100	6.375

ATR SALES INC. reserves the right to change design without notice. The dimensions and weights listed are approximate and sufficiently accurate for most users. The purchaser should use certified prints for construction where exact dimensions and weights are critical. Additional information will be provided if extreme accuracy is required.



# FLYWHEEL COUPLING DIMENSIONS

Patent #7,244,186

**ATRA-FLEX®**  
T-FLEX®

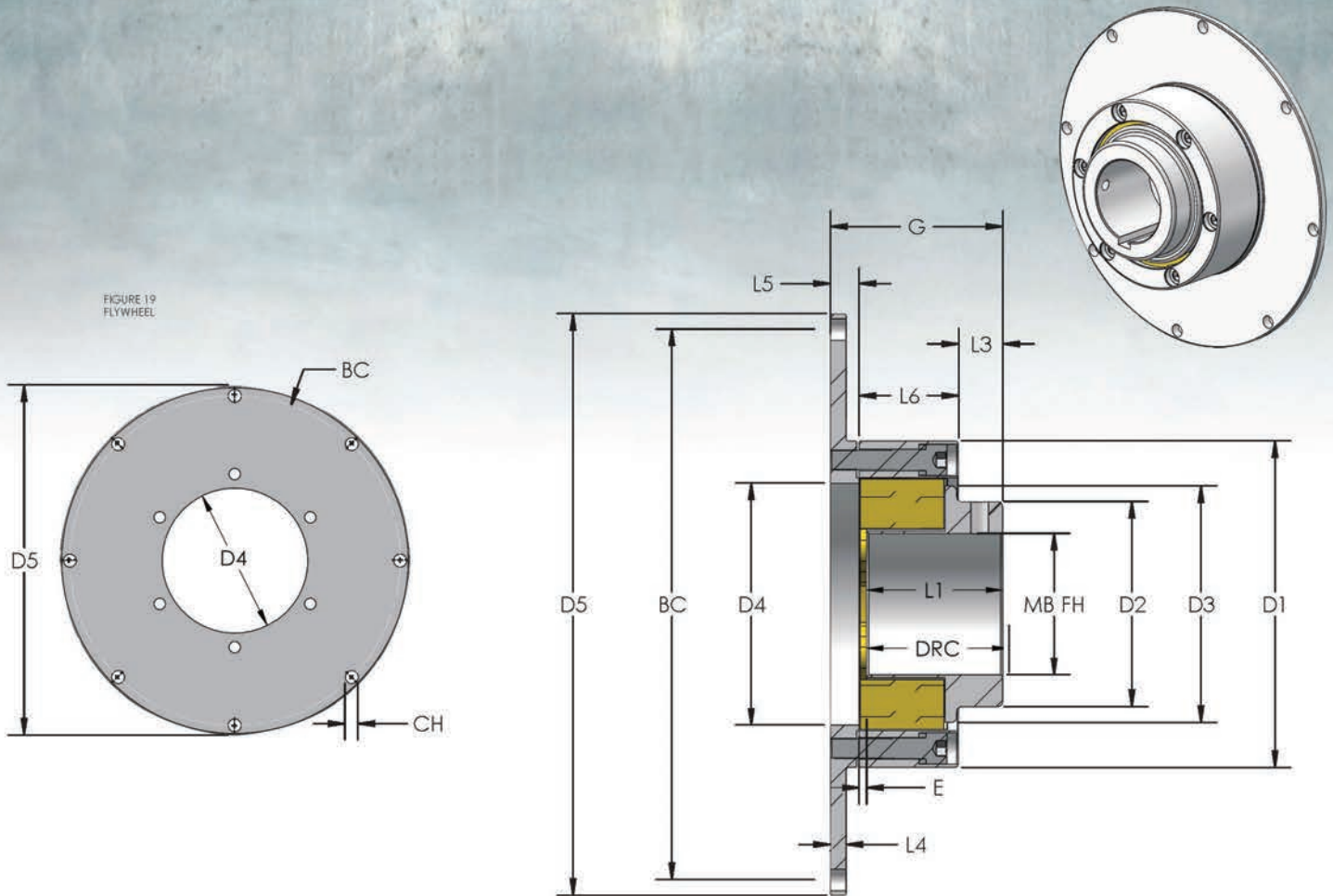

SIZE>	T-0	T-1	T-2	T-3	T-4	T-5	T-6	T-7	T-8	T-9	T-10	T-11	T-12
G	1.860	2.300	2.865	3.250	4.115	5.115	6.230	7.275	8.500	9.760	11.325	12.325	13.835
D1	2.950	3.960	4.800	6.290	7.800	9.765	11.900	13.600	14.625	18.020	19.950	23.250	28.500
MBFH	1.375	1.750	2.250	2.500	3.375	4.500	5.500	6.250	7.125	9.000	10.000	11.250	12.000
RSB	.300	.500	.600	.750	.950	1.000	1.500	1.750	2.250	2.900	3.700	3.900	3.900
E	.100	.100	.100	.100	.180	.180	.180	.200	.200	.200	.200	.250	.275
D2	1.995	2.585	3.200	4.000	4.900	6.500	7.875	9.250	10.167	12.775	14.625	16.000	18.500
D3	2.050	2.820	3.500	4.500	5.650	7.350	8.515	10.065	10.435	13.780	15.710	17.875	20.988
D4	2.470	2.920	3.600	4.625	5.775	7.475	8.640	10.190	10.560	13.905	15.835	18.000	21.115
L1	1.375	1.750	2.250	2.500	3.250	4.000	5.000	6.000	7.000	8.000	9.000	10.000	11.000
L3	.650	.705	1.200	1.125	1.115	1.325	2.475	2.485	3.250	3.875	4.140	4.250	4.900
L5	.375	.4375	.500	.625	.625	.875	1.000	1.125	1.250	1.500	2.000	2.000	2.500
L6	.835	1.165	1.165	1.500	2.375	2.875	2.715	3.795	3.900	4.385	5.185	6.100	6.375
S1	1.000	1.350	1.438	1.815	2.575	3.125	3.250	4.250	4.500	5.125	6.000	7.000	7.250

FLYWHEEL DIMENSIONS FOR STANDARD CLUTCH DIAMETERS											
SAE	6.5	7.5	8	10	11.5	14	16	18	21	24	
D5	8.500	9.500	10.375	12.375	13.875	18.375	20.375	22.500	26.500	28.875	
BC	7.875	8.750	9.625	11.625	13.125	17.250	19.250	21.375	25.250	27.250	
L4	.3125	.3125	.375	.375	.375	.375	.625	.750	.750	.750	
CH	.3281	.3281	.3906	.3906	.3906	.5156	.5156	.6406	.6406	.7656	
CHX	6	8	6	8	8	8	8	6	12	12	

**NOTE: CUSTOM FLYWHEELS AVAILABLE TO FIT MOST APPLICATIONS. STANDARD SPACER BODIES CAN BE ADDED. ALSO AVAILABLE AS LIMITED END FLOAT OR SLIDING.**

ATR SALES INC. reserves the right to change design without notice. The dimensions and weights listed are approximate and sufficiently accurate for most users. The purchaser should use certified prints for construction where exact dimensions and weights are critical. Additional information will be provided if extreme accuracy is required.



# FLOATING SHAFT COUPLING DIMENSIONS

Patent #7,244,186

**ATRA-FLEX®**  
T-FLEX®

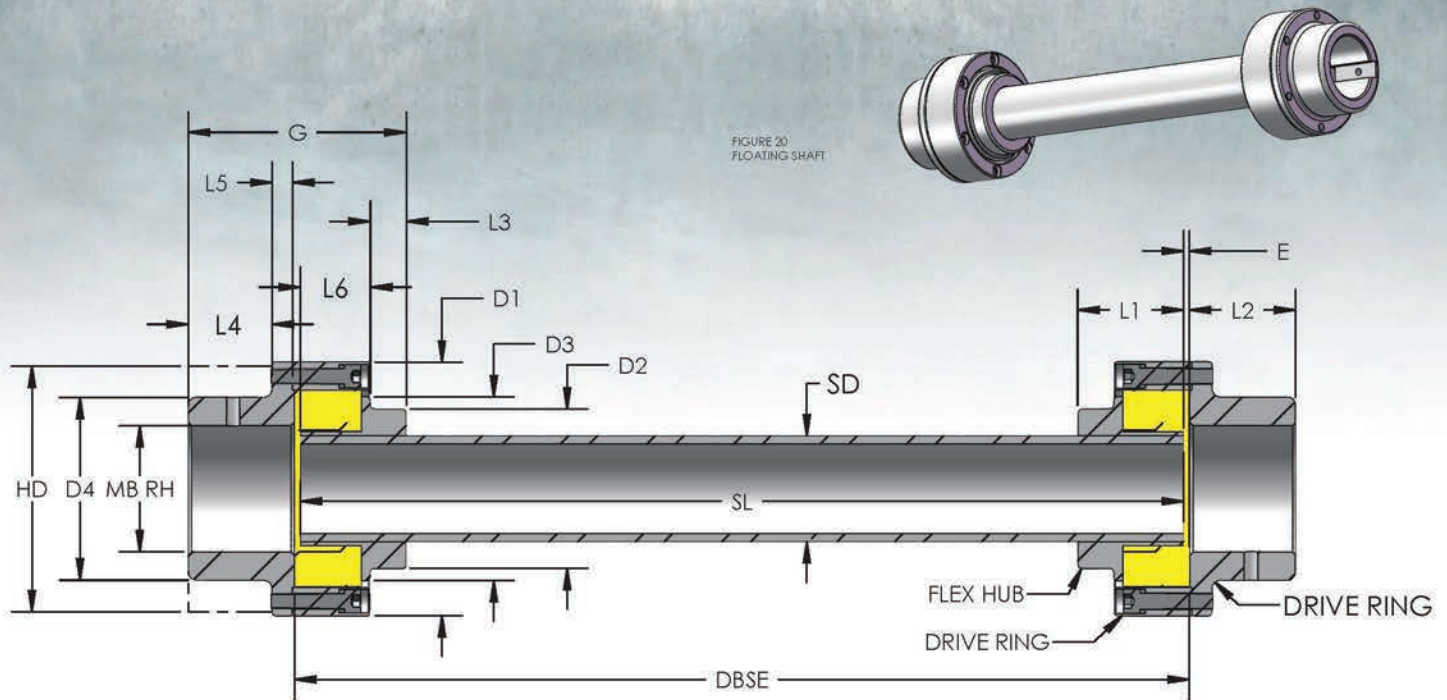

SIZE>	T-0	T-1	T-2	T-3	T-4	T-5	T-6	T-7	T-8	T-9	T-10	T-11	T-12
G	2.850	3.600	4.600	5.100	6.680	8.180	10.180	12.200	14.200	16.200	18.200	20.250	22.275
D1	2.950	3.960	4.800	6.290	7.800	9.765	11.900	13.600	14.625	18.020	19.950	23.250	28.500
MBFH	1.375	1.750	2.250	2.500	3.375	4.500	5.500	6.250	7.125	9.000	10.000	11.250	12.875
MBRH	1.625	2.250	2.500	3.375	3.875	5.250	6.250	7.250	7.625	10.375	12.000	12.500	15.000
MBHD	1.875	2.750	2.875	4.500	5.250	6.625	8.250	9.250	10.625	13.250	15.375	17.500	20.000
RSB	.300	.500	.600	.750	.950	1.000	1.500	1.750	2.250	2.900	3.700	3.900	3.900
E	.100	.100	.100	.100	.180	.180	.180	.200	.200	.200	.200	.250	.275
D2	1.995	2.585	3.200	4.000	4.900	6.500	7.875	9.250	10.167	12.775	14.625	16.000	18.500
D3	2.050	2.820	3.500	4.500	5.650	7.350	8.515	10.065	10.435	13.780	15.710	17.875	20.988
D4	2.470	3.200	3.625	5.000	5.625	7.500	8.875	10.750	11.375	13.875	16.500	17.500	22.875
HD	2.850	3.840	4.650	6.125	7.500	9.500	11.375	13.250	14.375	17.670	19.700	23.000	27.000
L1	1.375	1.750	2.250	2.500	3.250	4.000	5.000	6.000	7.000	8.000	9.000	10.000	11.000
L2	1.375	1.750	2.250	2.500	3.250	4.000	5.000	6.000	7.000	8.000	9.000	10.000	11.000
L3	.650	.705	1.200	1.125	1.115	1.325	2.475	2.485	3.250	3.875	4.140	4.250	4.900
L4	.980	1.295	1.730	1.825	2.565	3.065	3.940	4.925	5.690	6.440	6.875	7.900	8.440
L5	.375	.4375	.500	.625	.625	.875	1.000	1.125	1.250	1.500	2.000	2.000	2.500
L6	.835	1.165	1.165	1.500	2.375	2.875	2.715	3.795	3.900	4.385	5.185	6.100	6.375
DRC	1.450	2.085	2.500	2.700	4.250	5.175	4.865	6.815	7.140	8.010	9.570	11.100	11.675
SD	1.250	1.500	2.000	2.500	3.250	4.250	5.250	6.000	7.000	9.000	10.000	11.000	12.000

MBFH = MAX BORE FLEX HUB

MBRH = MAX BORE RING HUB MBHD = MAX BORE RING HUB HD

HD = RING HUB SMALL DIAMETER INCREASED FOR LARGER BORE CAPACITY

RSB = ROUGH STOCK BORE (MINIMUM RE-BORE)

ATR SALES INC. reserves the right to change design without notice. The dimensions and weights listed are approximate and sufficiently accurate for most users. The purchaser should use certified prints for construction where exact dimensions and weights are critical. Additional information will be provided if extreme accuracy is required.



# BRAKE WHEEL / BRAKE DISC DIMENSIONS

## PATENT # 7,244,186

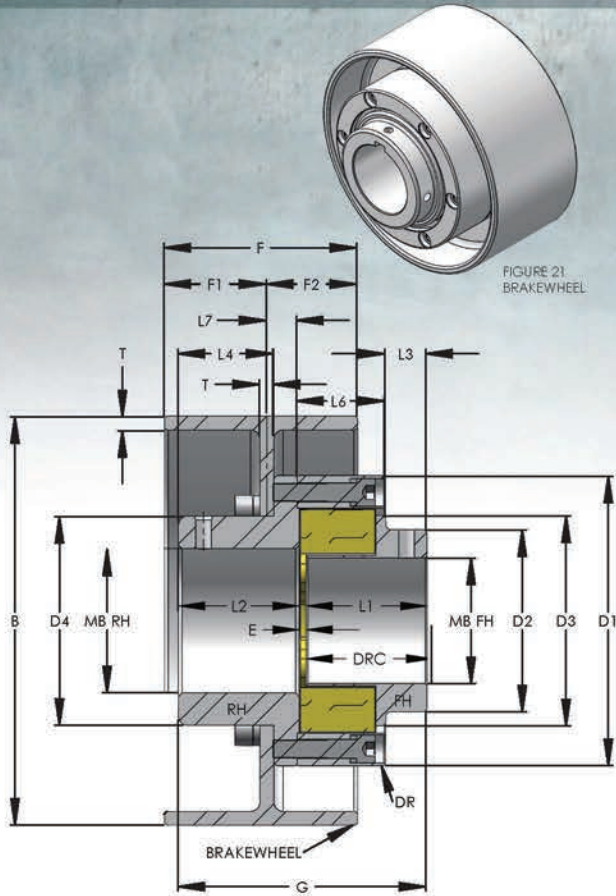

FIGURE 21  
BRAKEWHEEL

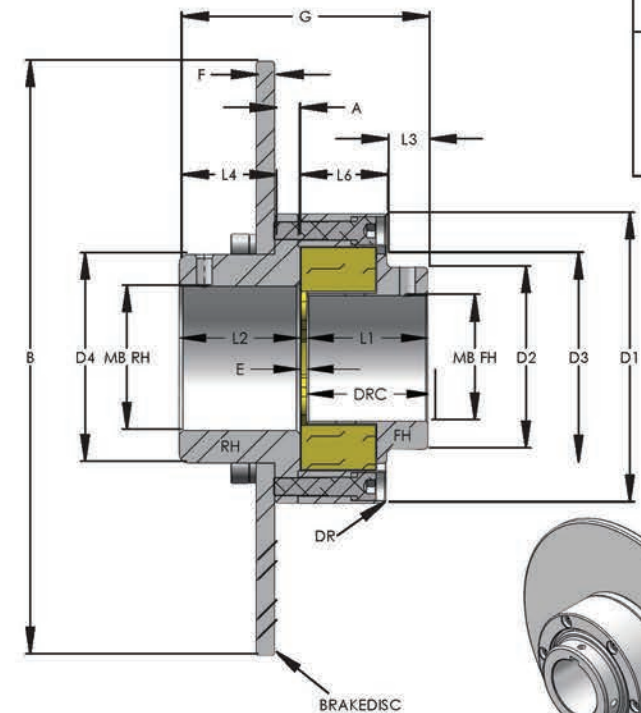

FIGURE 22  
BRAKEDISC

SIZE	WHEEL BXF	F1	F2	L7	T	DISC BXF	A
T-2	6 X 3.125 6 X 3.75	1.625 2.25	1.5	.645 6.45	.25 .25	8 X .25 10 X .25	.595
T-3	8 X 2.5 8 X 3.25 8 X 3.5	1.0 1.75 2.0	1.5	.865 .865 .865	.375 .375 .375	8 X .25 10 X .25 12 X .25	.675
T-4	10 X 3.75 10 X 4.25 10 X 5.5 11 X 5	1.0 2.0 3.25 2.75	2.25	.875 .875 .875 .875	.375 .375 .375 .375	10 X .25 12 X .25 16 X .5 18 X .5	.685
T-5	13 X 5.5 13 X 5.75 14 X 6.5 16 X 6.375 16 X 8.25 17 X 6.5	2.0 2.25 3.0 2.875 4.75 3.0	3.5	1.185 1.185 1.185 1.185 1.185 1.25	.5 .5 .5 .5 .5 .625	12 X .25 16 X .5 18 X .5 20 X .5 22 X .5	.935
T-6	14 X 6.5 16 X 6.375 16 X 8.25 17 X 6.5 19 X 8.25	3.0 2.875 4.75 3.0 4.75	3.5	1.3 1.3 1.3 1.365 1.425	.5 .5 .5 .625 .75	16 X .5 18 X .5 20 X .5 22 X .5 24 X .5	1.05
T-7	17 X 6.5 19 X 8.25 19 X 8.75 20 X 8.25 23 X 8.25 23 X 9.25	2.5 4.25 4.75 4.25 4.25 5.25	4.0	1.495 1.56 1.56 1.56 1.56 1.56	.625 .750 .750 .750 .750 .750	18 X .5 20 X .5 22 X .5 24 X .5 30 X .5	1.185
T-8	19 X 8.25 19 X 8.75 20 X 8.25 23 X 8.25 23 X 9.25 24 X 10 25 X 10.25	4.25 4.75 4.25 4.25 5.25 6.0 6.25	4.0	1.685 1.685 1.685 1.685 1.685 1.75 1.81	.750 .750 .750 .750 .750 .875 1.0	20 X .5 22 X .5 24 X .5 30 X .5 36 X .625	1.31
T-9	23 X 8.25 23 X 9.25 24 X 10 25 X 10.25 26 X 10.25 28 X 11.25	3.25 4.25 5.0 5.25 5.25 6.25	5.0	1.935 1.935 2.0 2.06 2.06 1.185	.750 .750 .875 1.0 1.0 1.25	24 X .5 30 X .5 36 X .625 40 X .625	1.560

SIZE>	T-2	T-3	T-4	T-5	T-6	T-7	T-8	T-9
G	4.600	5.100	6.680	8.180	10.180	12.200	14.200	16.200
D1	4.800	6.290	7.800	9.765	11.900	13.600	14.625	18.020
MBFH	2.250	2.500	3.375	4.500	5.500	6.250	7.125	9.000
MBRH	2.500	3.375	3.875	5.250	6.250	7.250	7.625	10.375
E	.100	.100	.180	.180	.180	.200	.200	.200
D2	3.200	4.000	4.900	6.500	7.875	9.250	10.167	12.775
D3	3.500	4.500	5.650	7.350	8.515	10.065	10.435	13.780
D4	3.625	5.000	5.625	7.500	8.875	10.750	11.375	13.875
L1	2.250	2.500	3.250	4.000	5.000	6.000	7.000	8.000
L2	2.250	2.500	3.250	4.000	5.000	6.000	7.000	8.000
L3	1.200	1.125	1.115	1.325	2.475	2.485	3.250	3.875
L4	1.730	1.825	2.565	3.065	3.940	4.925	5.690	6.440
L5	.500	.625	.625	.875	1.000	1.125	1.250	1.500
L6	1.165	1.500	2.375	2.875	2.715	3.795	3.900	4.385
DRC	2.500	2.700	4.250	5.175	4.865	6.815	7.140	8.010
S1	1.438	1.815	2.575	3.125	3.250	4.250	4.500	5.125
S2	1.125	1.250	1.625	2.000	2.500	3.000	3.500	4.000
SS	3/8	3/8	1/2	5/8	3/4	1-8	1-8	1-8

ATR SALES INC. reserves the right to change design without notice. The dimensions and weights listed are approximate and sufficiently accurate for most users. The purchaser should use certified prints for construction where exact dimensions and weights are critical. Additional information will be provided if extreme accuracy is required.



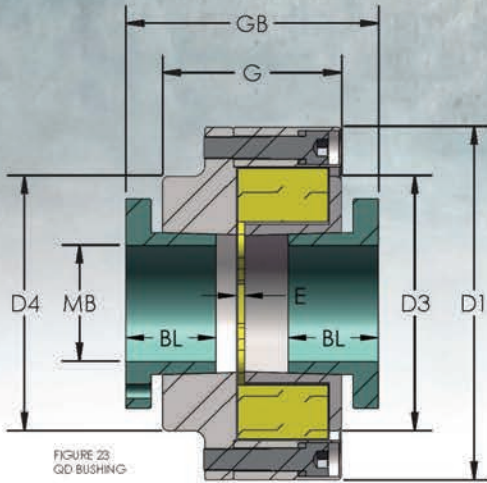

**QD BUSHING**

SIZE	QD	MB	GB	G	D1	D3	D4	E	BL
T-0	JA	1.250	2.550	1.550	2.950	2.050	2.470	.100	1.062
T-1	SH	1.625	3.850	2.725	3.960	2.820	3.200	.100	1.312
T-2	SD	2.000	3.975	2.725	4.800	3.500	3.625	.100	1.812
T-3	SK	2.500	5.540	4.165	6.290	4.500	5.000	.100	1.937
T-4	SF	2.875	5.250	3.830	7.800	5.650	5.625	.180	2.062
T-5	F	4.000	7.805	5.805	9.765	7.350	7.500	.180	3.625
T-6	J	4.500	9.555	7.180	11.900	8.515	8.875	.180	4.500
T-7	M	5.500	14.075	11.200	13.600	10.065	10.750	.200	6.750
T-8	N	6.000	16.700	13.450	14.625	10.435	11.375	.200	8.125
T-9	P	7.000	19.825	15.825	18.020	13.780	13.875	.200	9.375
T-10	W	8.000	23.575	19.075	19.950	15.710	16.500	.200	11.37

NOTE: RING HUBS MAY ACCOMMODATE +1 SIZE LARGER BUSHING THAN FLEX HUB

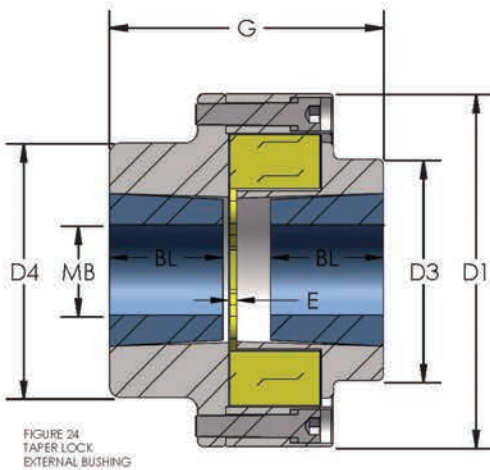

**TAPER LOCK BUSHING EXTERNAL**

SIZE	TL-EXT	MB	G	D1	D3	D4	E	BL
T-0	1008	1.000	2.475	2.950	2.050	2.470	.100	.875
T-1	1108	1.125	2.850	3.960	2.820	3.200	.100	.875
T-2	1615	1.687	3.975	4.800	3.500	3.625	.100	1.500
T-3	2012	2.125	3.975	6.290	4.500	5.000	.100	1.250
T-4	2525	2.500	6.055	7.800	5.650	5.625	.180	2.500
T-5	3020	3.250	6.305	9.765	7.350	7.500	.180	2.000
T-6	4040	4.437	9.305	11.900	8.515	8.875	.180	4.000
T-7	5050	5.000	11.325	13.600	10.065	10.750	.200	5.000
T-8	5050	6.000	12.325	14.625	10.435	11.375	.200	5.000
T-9	7060	7.000	14.325	18.020	13.780	13.875	.200	6.000
T-10	8065	8.000	15.950	19.950	15.710	16.500	.200	6.500

NOTE: RING HUBS MAY ACCOMMODATE +1 SIZE LARGER BUSHING THAN FLEX HUB

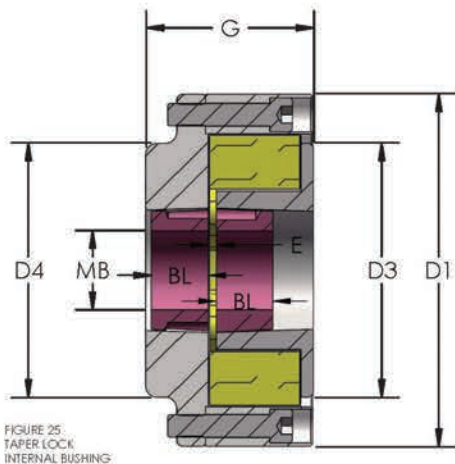

**TAPER LOCK BUSHING INTERNAL**

SIZE	TL-INT	MB	G	D1	D3	D4	E	BL
T-1	1108	1.125	2.140	3.960	2.820	3.200	.100	.875
T-2	1310	1.437	2.300	4.800	3.500	3.625	.100	1.000
T-3	1610	1.687	2.625	6.290	4.500	5.000	.100	1.000
T-4	2012	2.125	3.705	7.800	5.650	5.625	.180	1.250
T-5	3020	3.250	5.030	9.765	7.350	7.500	.180	2.000
T-6	3535	3.937	7.430	11.900	8.515	8.875	.180	3.500
T-7	4040	4.437	8.450	13.600	10.065	10.750	.200	4.000
T-8	4545	4.937	9.450	14.625	10.435	11.375	.200	4.500
T-9	5050	5.000	10.450	18.020	13.780	13.875	.200	5.000
T-10	6050	6.000	10.450	19.950	15.710	16.500	.200	5.000

NOTE: RING HUBS MAY ACCOMMODATE +1 SIZE LARGER BUSHING THAN FLEX HUB



**ALIGNMENT TOLERANCES**

SIZE>	T-0	T-1	T-2	T-3	T-4	T-5	T-6	T-7	T-8	T-9	T-10	T-11	T-12
GAP E	.100	.100	.100	.100	.180	.180	.180	.200	.200	.200	.200	.250	.275
E +	.100	.125	.125	.175	.175	.225	.225	.250	.250	.250	.350	.350	.350
E -	.020	.030	.030	.040	.040	.050	.050	.070	.070	.070	.070	.070	.100
PARALLEL O	.450	.570	.650	.895	1.075	1.207	1.692	1.767	2.095	2.120	2.120	2.687	3.756
O +/-	.020	.030	.030	.030	.040	.040	.040	.040	.040	.045	.050	.075	.075
TIR	.040	.060	.060	.060	.080	.080	.080	.080	.080	.090	.100	.150	.150
ANGULAR A*	2	2	2	2	1	1	1	1	1	1	1	1	1
D1	2.950	3.960	4.800	6.290	7.800	9.765	11.900	13.600	14.625	18.020	19.950	23.250	28.500
D3	2.050	2.820	3.500	4.500	5.650	7.350	8.515	10.065	10.435	13.780	15.710	17.875	20.988
TH-UNF	6-32	10-32	1/4	5/16	1/2	1/2	5/8	5/8	3/4	7/8	1	1 1/8	1 1/2
TT IN-LBS	31	85	210	415	1900	1900	3500	3500	6200	8500	12300	15500	46500

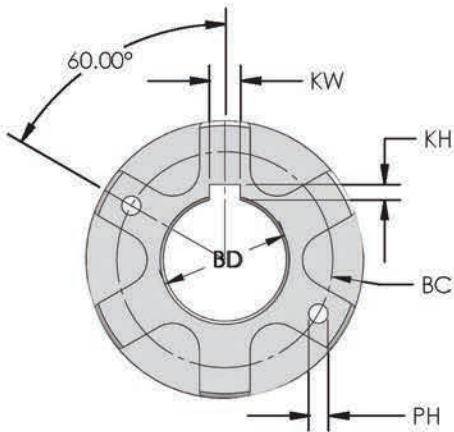
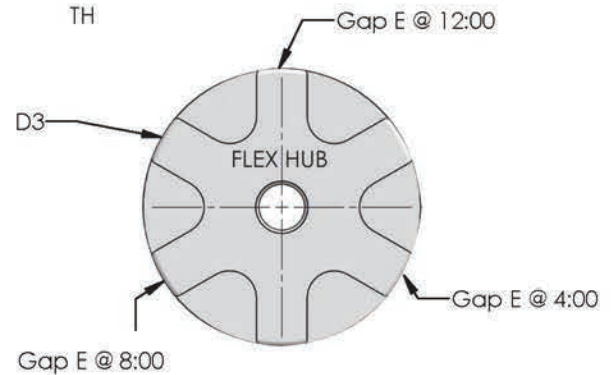
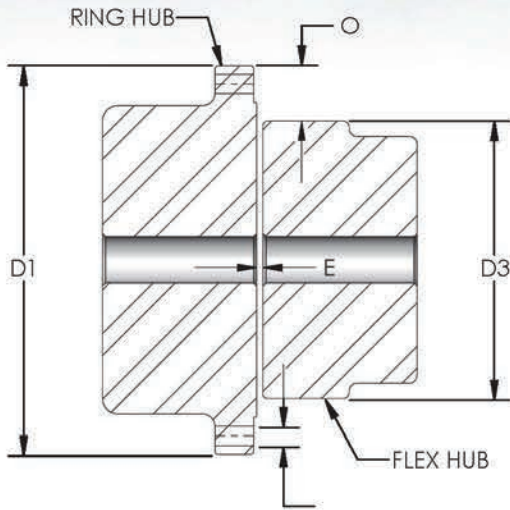

**BORE/KEYWAY CHART**

BD	KW X KH	BD	KW X KH
1/2 - 9/16	1/8 X 1/16	3 5/16 - 3 3/4	7/8 X 7/16
5/8 - 7/8	3/16 X 3/32	3 13/16 - 4 1/2	1 X 1/2
1 5/16 - 1 1/4	1/4 X 1/8	4 9/16 - 5 1/2	1 1/4 X 5/8
1 5/16 - 1 3/8	5/16 X 5/32	5 9/16 - 6 1/2	1 1/2 X 3/4
1 7/16 - 1 3/4	3/8 X 3/16	6 9/16 - 7 1/2	1 3/4 X 7/8
1 13/16 - 2 1/4	1/2 X 1/4	7 9/16 - 9	2 X 1
2 5/16 - 2 3/4	5/8 X 5/16	9 1/16 - 11	2 1/2 X 7/8
2 3/16 - 3 1/4	3/4 X 3/8	11 - 13	3 X 1

SLIP FIT BORES = NOMINAL SHAFT DIAMETER +.001/+.002  
SUPPLIED WITH STANDARD KEYWAY AND TWO SET SCREW (1 OVER KEYWAY & 1 @90)

INTERFERENCE FIT BORES = NOMINAL SHAFT DIAMETER X .0005 = INTERFERENCE +/- .0005  
SUPPLIED WITH STANDARD KEYWAY AND ONE SET SCREW OVER KEYWAY

ALL SPLINED AND TAPER BORES ARE AVAILABLE WITH EXTRA CHARGE & LEAD TIME  
FACTORY DYNAMIC BALANCING IS AVAILABLE WITH EXTRA CHARGE & LEAD TIME

**FLEX HUB PULLER HOLES (OPTIONAL)**

SIZE>	T-1	T-2	T-3	T-4	T-5	T-6	T-7	T-8	T-9	T-10	T-11	T-12
PH	1/4	1/4	5/16	1/2	1/2	5/8	5/8	3/4	7/8	1	1 1/8	1 1/2
BC	2.285	2.875	3.500	4.525	5.925	7.000	8.150	8.500	11.400	13.350	14.650	16.494

NOTE: THE STANDARD RING HUB BOLT PATTERN CAN BE USED AS PULLER HOLES



DRIVER F1	SF
ELECTRIC MOTOR	1.0
GAS OR STEAM TURBINE	1.0
GEAR BOX INCREASER / REDUCER	1.0
GAS OR DIESEL ENGINE 4+ CYL	3.0
GAS OR DIESEL ENGINE 1-3 CYL	4.0

DRIVEN F2	SF
GENERATORS, GEAR BOXES, LIGHT DUTY AGITATORS & CONVEYERS, STOKERS	1.0
CENTRIFUGAL PUMPS, COMPRESSORS, BLOWERS, FANS, ETC.	1.0
RECIPROCATING PUMPS, COMPRESSORS, FEEDERS, FREQUENT STOPS/STARTS, ETC.	2.0
PULP & PAPER MILL EQUIPMENT (REFER TO MILL STANDARD COUPLING SF GUIDE)	1-3
STEEL MILL EQUIPMENT (REFER TO MILL STANDARD COUPLING SF GUIDE)	1-3

1) Determine service factor (SF)  
SF = F1 X F2 (not to exceed 4)

2) Calculate required coupling continuous torque rating (lb-in)  
using the formula: HP X SF X 63025 + RPM = Torque (lb-in)

3) Determine suitable coupling insert type for application using the Insert Color Chart below

INSERT TYPE	DESCRIPTION	USE	MAX TEMP °F	MIN TEMP °F	DUROMETER
YELLOW	GENERAL USE, HIGH DAMPEN	GENERAL APPLICATIONS (STANDARD)	250	-60	60D
RED	HIGH TEMPERATURE, HIGH DAMPEN	HIGH TEMPERATURE RUNNING APPLICATIONS	350	-20	90A
ORANGE	HIGH TORQUE, MEDIUM DAMPEN	HIGH TORQUE, LOW SPEED APPLICATIONS	250	-20	70D
BROWN	HIGH DAMPENING	HEAVY VIBRATION, SHOCK LOADS	250	-60	95A

4) Choose the coupling size that meets or exceeds the calculated required continuous torque rating using the color coded tables below.  
Intermittent (peak) ratings are reserved for system torque spikes, starts/stops, reversing etc.

Insert Tables: Torque ratings (lb-in) - HP ratings @ various RPMs - Max RPMs based on insert types

INSERT YELLOW	A00	A0	A1	A2	A3	A4	A5	A6	A7	A8	A9	A11
CONTINUOUS (LB-IN)	105	265	340	1325	2650	5300	13230	21200	42350	79400	120300	300000
INTERMITTENT (LB-IN)	1.76	411	819	2205	4410	8820	22050	35280	70560	132300	200500	500000
HP @ 100 RPM (SF1)	0.17 0.28	0.42 0.70	0.54 1.30	2.10 3.50	4 7	8 14	21 35	34 56	67 112	126 210	191 318	476 793
HP @ 1200 RPM (SF1)	2.00 3.35	5.05 8	6 16	25 42	50 84	101 168	252 420	404 672	806 1343	1512 2519	2291 3818	5712 9520
HP @ 1750 RPM (SF1)	2.92 4.89	7 12	9 23	37 61	74 122	147 245	367 612	589 980	1176 1959	2205 3674	3340 5567	8330 13883
HP @ 3600 RPM (SF1)	6.00 10.05	15 25	19 47	76 126	151 252	303 504	756 1260	1211 2015	2419 4030	4535 7557	6872 11453	17136 28560
MAX RPM UNBALANCED	14000	9800	7300	5400	4200	3600	2600	2200	1900	1600	1360	1150
MAX RPM BALANCED G2.5	20200	12200	11000	9000	7000	5300	4200	3400	2900	2400	2100	1700

INSERT RED	A00	A0	A1	A2	A3	A4	A5	A6	A7	A8	A9	A11
CONTINUOUS (LB-IN)	89	225	289	1126	2253	4505	11246	18020	35998	67490	102255	255000
INTERMITTENT (LB-IN)	1.50	349	696	1874	3749	7497	18743	29988	59976	112455	170425	425000
HP @ 100 RPM (SF1)	0.14 0.24	0.36 0.60	0.46 1.11	1.79 2.98	3 6	7 12	18 30	29 48	57 95	107 179	162 270	405 674
HP @ 1200 RPM (SF1)	1.70 2.85	4.29 7	5 14	21 36	43 71	86 143	214 357	343 571	685 1142	1285 2141	1947 3245	4855 8092
HP @ 1750 RPM (SF1)	2.48 4.16	6 10	8 20	31 52	63 104	125 208	312 520	501 833	1000 1665	1874 3123	2839 4732	7081 11801
HP @ 3600 RPM (SF1)	5.10 8.54	13 21	16 40	65 107	128 104	258 428	643 1071	1029 1713	2056 3426	3655 6423	5841 9735	14566 24276
MAX RPM UNBALANCED	14000	9800	7300	5400	4200	3600	2600	2200	1900	1600	1360	1150
MAX RPM BALANCED G2.5	20200	12200	11000	9000	7000	5300	4200	3400	2900	2400	2100	1700

INSERT ORANGE	A00	A0	A1	A2	A3	A4	A5	A6	A7	A8	A9	A11
CONTINUOUS (LB-IN)	200	503	646	2518	5035	10070	25137	40280	80465	150860	228570	570000
INTERMITTENT (LB-IN)	334	838	1556	4190	8379	16758	41895	67032	134064	251370	380950	950000
HP @ 100 RPM (SF1)	0.32 0.53	0.80 1.33	1.02 2.47	4.00 6.65	8 13	16 27	40 66	64 106	128 213	239 399	363 604	904 1507
HP @ 1200 RPM (SF1)	3.81 6.36	9.58 16	12 30	48 80	96 160	192 319	479 798	767 1276	1532 2553	2872 4786	4352 7253	10853 18088
HP @ 1750 RPM (SF1)	5.55 9.27	14 23	18 43	70 116	140 233	280 465	698 1163	118 1861	2234 3723	4189 6980	6347 10578	15827 26378
HP @ 3600 RPM (SF1)	11.42 19.08	29 48	37 89	144 239	288 479	575 957	1436 2393	2301 3829	4602 7557	8404 13423	12808 21145	32216 52250
MAX RPM UNBALANCED	14000	9800	7300	5400	4200	3600	2600	2200	1900	1600	1360	1150
MAX RPM BALANCED G2.5	20200	12200	11000	9000	7000	5300	4200	3400	2900	2400	2100	1700

INSERT BROWN	A00	A0	A1	A2	A3	A4	A5	A6	A7	A8	A9	A11
CONTINUOUS (LB-IN)	85	214	275	1070	2140	4280	10683	17119	34198	64116	97142	242250
INTERMITTENT (LB-IN)	1.42	356	661	1781	3561	7122	17805	28489	56977	106832	161904	403750
HP @ 100 RPM (SF1)	0.13 0.23	0.34 0.57	0.44 1.05	1.70 2.83	3 6	7 11	17 28	27 45	54 90	102 170	154 257	384 641
HP @ 1200 RPM (SF1)	1.62 2.70	4.07 7	5 13	20 34	41 68	81 136	203 339	326 542	651 1065	1221 2034	1850 3063	4612 7687
HP @ 1750 RPM (SF1)	2.36 3.94	6 10	8 18	30 49	59 99	119 198	297 494	475 791	950 1582	1780 2966	2697 4496	6726 11211
HP @ 3600 RPM (SF1)	4.86 8.11	12 20	16 38	61 102	122 203	244 407	610 1017	978 1627	1953 3255	3662 6102	5549 9248	9764 16273
MAX RPM UNBALANCED	14000	9800	7300	5400	4200	3600	2600	2200	1900	1600	1360	1150
MAX RPM BALANCED G2.5	20200	12200	11000	9000	7000	5300	4200	3400	2900	2400	2100	1700

5) Determine coupling type required for the application. Check dimensions/max bore tables to confirm the coupling sized will accommodate shafts and physically fit the application. Determine if the couplings hubs will be bored to size, or used with Taper Lock Bushings, QD Bushings, or other type of locking device. Standard couplings are machined carbon steel. Specify if stainless steel or Melonite Process is required based on atmosphere conditions, etc.

Listed service factors are intended as a general guide, and are typical of usual service requirements.  
Please refer to AGMA 922-A96: Load Classification and Service Factors for Flexible Couplings for a complete list.



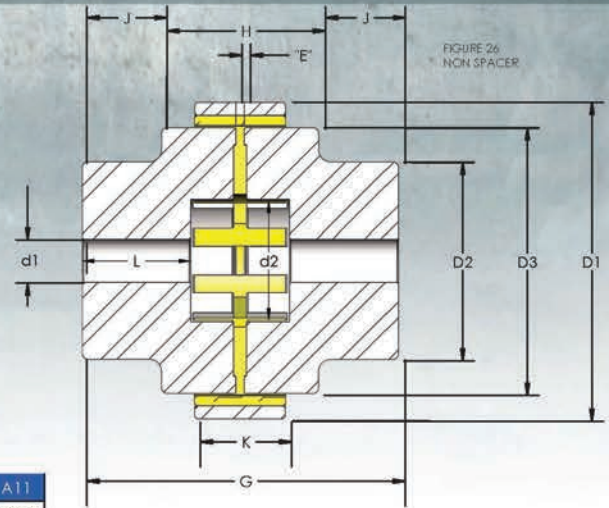
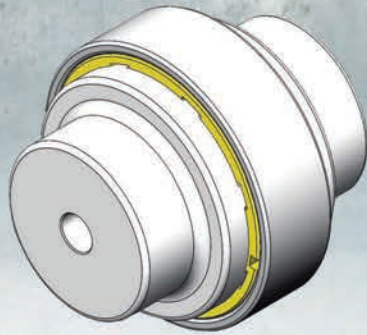

**DIMENSIONS - A-SERIES®**

SIZE (in inches)	A00	A0	A1	A2	A3	A4	A5	A6	A7	A8	A9	A11
EXTERNAL D1	1.80	2.50	3.15	4.25	5.56	7.00	8.900	10.625	12.400	14.45	16.925	20.00
TOTAL LENGTH G	2.10	2.79	3.56	4.83	5.98	6.99	8.61	10.19	12.19	14.19	16.22	20.10
MAXIMUM BORE d1	0.88	1.25	1.63	1.94	2.38	2.94	4.00	5.00	6.00	7.13	9.25	10.50
PILOT BORE	0.25	0.30	0.43	0.50	0.63	0.95	1.13	1.50	1.75	2.45	2.90	3.74
L	.765	1.06	1.34	1.775	2.13	2.40	3.07	3.750	4.57	5.36	6.225	7.450
d2	0.88	1.23	1.40	1.65	2.00	2.70	3.35	4.45	5.25	5.93	7.35	7.75
D2	1.35	1.995	2.37	3.07	3.52	4.36	5.79	7.25	8.00	9.50	11.00	13.00
D3	1.385	2.065	2.505	3.36	4.505	5.872	7.45	9.225	10.49	12.80	15.087	17.90
H	0.90	1.06	1.39	2.03	2.42	3.48	3.93	4.69	4.99	5.99	6.41	9.10
J	0.60	0.87	1.100	1.40	1.78	1.755	2.34	2.75	3.60	4.10	4.905	5.50
K	0.50	0.55	0.88	1.25	1.63	2.03	2.310	2.750	3.00	3.35	3.750	5.00
E (GAP)	0.047	0.062	0.062	0.062	0.062	0.188	0.188	0.188	0.188	0.188	0.219	0.100
APPROX WT (LBS)	0.78	2.24	4.00	9.26	17.00	33.18	67.68	115.00	175.00	308.00	456.00	770.00

Note: on Heavy Duty (maximum bore) hubs - D2 will be same as D3

**A-Series® Floater Couplings**

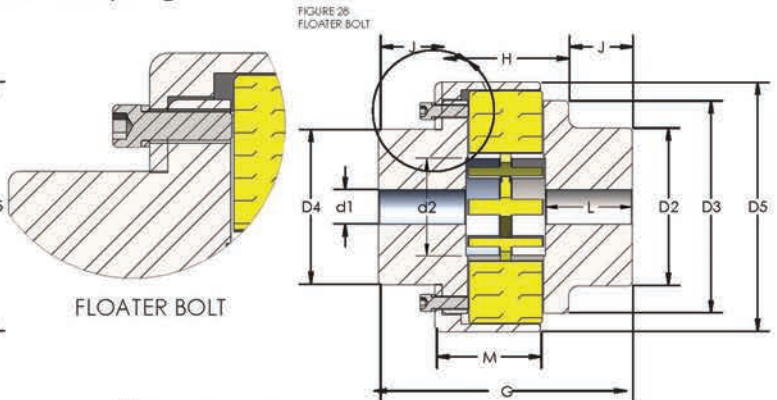
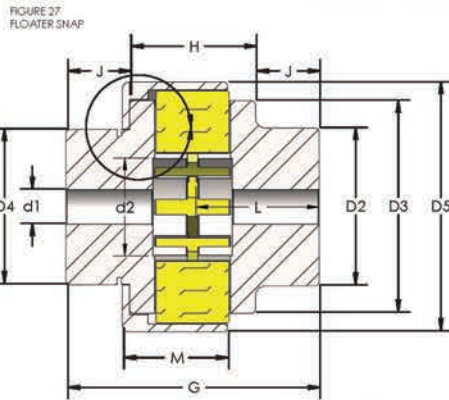

**DIMENSIONS - A-SERIES® FLOATER**

SIZE (in inches)	A00	A0	A1	A2	A3	A4	A5	A6	A7	A8	A9	A11
EXTERNAL D5	N/A		3.150	4.250	5.600	6.950	8.750	10.750	12.250	14.375	16.835	
TOTAL LENGTH G	2.10	2.79	3.56	4.83	5.98	6.99	8.61	10.19	12.19	14.19	16.22	20.10
MAXIMUM BORE d1	0.88	1.25	1.63	1.94	2.38	2.94	4.00	5.00	6.00	7.13	9.25	10.50
PILOT BORE	0.25	0.30	0.43	0.50	0.63	0.95	1.13	1.50	1.75	2.45	2.90	3.74
L	0.78	1.06	1.34	1.78	2.13	2.40	3.07	3.70	4.57	5.36	6.17	7.75
d2	0.88	1.23	1.40	1.65	2.00	2.70	3.35	4.45	5.25	5.93	7.35	7.75
D2	1.35	2.00	2.37	3.07	3.52	4.36	5.79	7.25	7.80	9.50	11.00	13.00
D3	1.39	2.07	2.51	3.36	4.51	5.87	7.45	9.25	10.49	12.80	15.09	17.90
H	0.90	1.06	1.39	2.03	2.42	3.48	3.93	4.69	4.99	5.99	6.41	9.10
J	0.60	0.87	1.09	1.40	1.78	1.76	2.34	2.75	3.60	4.10	4.91	5.50
M	N/A		1.336	1.425	2.400	2.900	3.300	4.000	4.625	5.100	5.600	
E (GAP)	0.047	0.062	0.062	0.062	0.062	0.188	0.188	0.188	0.188	0.188	0.219	0.100
APPROX WT (LBS)	0.78	2.24	4.00	9.26	17.00	33.18	67.68	115.00	175.00	308.00	456.00	770.00

ATR SALES INC. reserves the right to change design without notice. The dimensions and weights listed are approximate and sufficiently accurate for most users. The purchaser should use certified prints for construction where exact dimensions and weights are critical. Additional information will be provided if extreme accuracy is required.



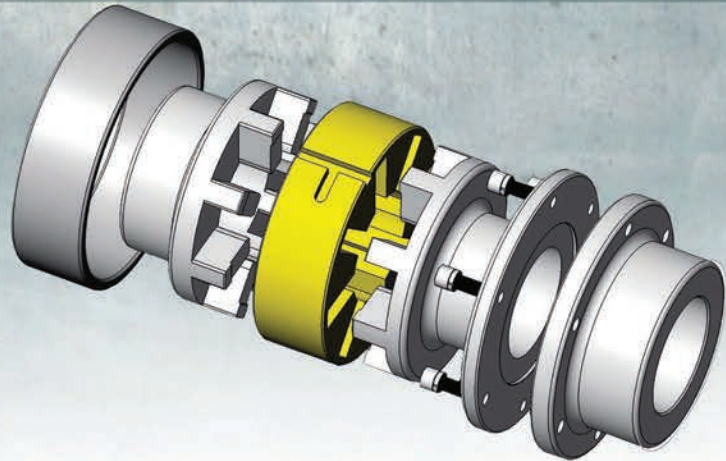
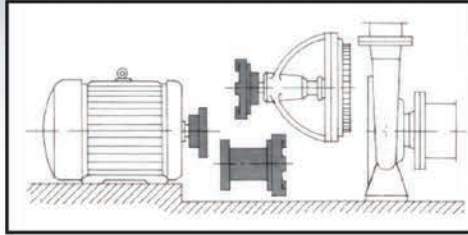
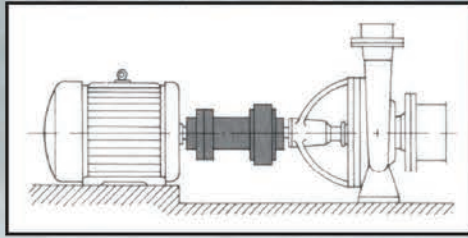
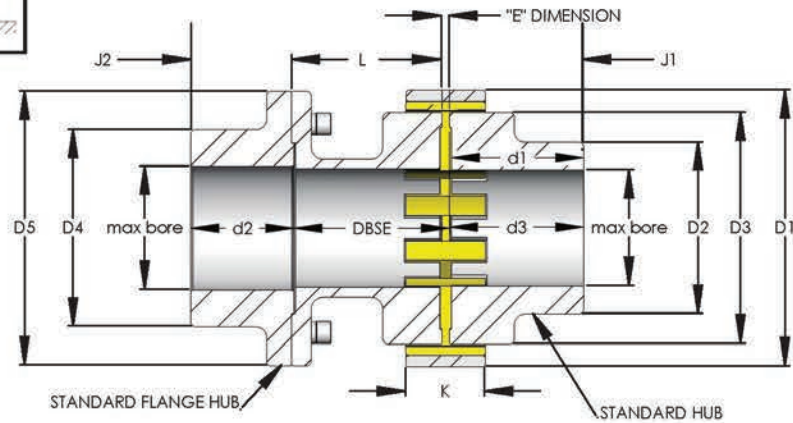

FIGURE 29  
SPACER



NOTES:  
 SPACER BODY (L) IS ORDERED BY DISTANCE BETWEEN SHAFT ENDS (DBSE)  
 \*\* SPACER BODY IS SHORTENED BY THE "E" DIMENSION AT THE FACTORY  
 \*\*\* STD. HUB SIDE SHAFT END IS INSTALLED SO THAT THE END OF SHAFT IS PERPENDICULAR WITH THE END OF THE WINGS ON THE HUB  
 \*\*\*\* CAN BE ORDERED TO MEET ALL API STANDARDS 610 / 7TH EDITION

**DIMENSIONS (IN INCHES)**

SIZE	A0	A1	A2	A3	A4	A5	A6	A7	A8	A9	A11	
EXTERNAL D1	2.500	3.150	4.250	5.560	7.000	8.890	10.680	12.120	14.450	16.950	20.000	
MAXIMUM BORE HUB	1.250	1.625	1.9375	2.375	2.9375	4.000	5.000	6.000	7.125	9.250	10.500	
MAXIMUM BORE FLANGE HUB	1.375	1.875	2.375	2.875	3.375	4.000	5.000	5.750	7.125	8.250	10.500	
*MAX BORE HEAVY DUTY FLANGE					3.875*	5.000*	6.875*	7.125	8.875*	9.250*	11.875*	
PILOT BORE	0.300	0.430	0.500	0.625	0.950	1.130	1.500	1.750	2.450	2.900	3.740	
d1	1.055	1.340	1.775	2.130	2.400	3.070	3.700	4.570	5.360	6.165	7.750	
d2	1.450	1.620	2.125	2.410	2.610	3.410	4.312	4.625	7.000	9.100	9.850	
d3	1.365	1.750	2.325	2.900	3.340	4.150	4.940	5.940	6.940	7.940	9.940	
D2	1.995	2.370	3.070	3.520	4.360	5.790	7.250	7.800	9.500	11.000	13.000	
D3	2.065	2.505	3.360	4.505	5.872	7.450	9.250	10.490	12.800	15.087	17.900	
D4 (FOR HEAVY DUTY FLANGE USE D5)	2.280	2.875	3.500	4.200	5.000	6.300	7.250	8.375	10.000	11.000	14.000	
D5	3.415	3.940	4.710	5.515	6.950	8.860	10.000	10.490	12.800	15.087	17.900	
J1	1.365	1.750	2.385	2.960	3.400	4.210	5.000	6.000	7.000	8.000	10.000	
J2	1.390	1.560	2.065	2.350	2.550	3.350	4.252	4.565	6.900	9.000	9.750	
K	0.550	0.875	1.250	1.625	2.025	2.325	2.775	3.025	3.350	3.775	5.000	
E (GAP)	0.062	0.062	0.062	0.062	0.188	0.188	0.188	0.188	0.188	0.219	0.100	
STANDARD BODY LENGTH		3.0 3.5 3.75 4.0 4.5 5.0	3.0 3.5 3.75 4.0 5.0 7.0	3.5 3.75 5.0 5.25 5.5 7.0 7.25 7.5	4.0 5.0 6.0 7.0 9.5 9.75	5.0 6.0 7.0 7.25 9.75 10.0 12.0		7.0 TO 14.0	7.0 TO 18.0	7.5 TO 18.0	9.5 TO 18.0	9.5 TO 20.0
CUSTOM LENGTHS AVAILABLE WITH EXTRA CHARGE	3.0 3.5											

SEE TABLE 1 FOR HORSEPOWER CAPACITY AT VARIOUS RPM

ATR SALES INC. reserves the right to change design without notice. The dimensions and weights listed are approximate and sufficiently accurate for most users. The purchaser should use certified prints for construction where exact dimensions and weights are critical. Additional information will be provided if extreme accuracy is required.



**TABLE 25: STANDARD KEYWAYS**

BORE SIZE	KEY WAY	BORE SIZE	KEY WAY	BORE SIZE	KEY WAY	BORE SIZE	KEYWAY
.500 to .5625	.125 X .0625	1.4375 X 1.750	.375 X .1875	3.3125 to 3.750	.875 X .4375	6.5625 to 7.500	1.750 X .875
.625 to .875	.1875 X .09375	1.8125 X 2.250	.500 X .250	3.8125 to 4.500	1.000 X .500	7.5625 to 9.000	2.000 X 1.000
.9375 to 1.250	.250 X .125	2.3125 X 2.750	.625 X .3125	4.5625 to 5.500	1.250 X .625	9.0625 to 11.000	2.500 X 1.250
1.3125 to 1.375	.3125 X .15625	2.8125 X 3.250	.750 X .375	5.5625 to 6.500	1.500 X .750		

**TABLE 26: TOLERANCES FOR BORES**

Cplg Size	Type of Bore	Bore Range	Tolerances
00 thru 6	AGMA Class 2 Clearance Fit	Up to 4"	+0.002 -.000
7 thru 13	Custom or Int. Fit	3" and over	+0.000 -.002

**TABLE 27: A-SERIES® TOLERANCES - RADIAL, AXIAL, ANGULAR**

SIZE	A00	A0	A1	A2	A3	A4	A5	A6	A7	A8	A9	A10	A11
DISTANCE BETWEEN HUBS	.047	.062	.062	.062	.062	.188	.188	.188	.188	.188	.219	.250	.100
RADIAL TOLERANCE	.02	.02	.039	.039	.058	.058	.058	.058	.058	.058	.078	.078	.078
AXIAL TOLERANCE	+0.039	+0.039	+0.058	+0.058	+0.078	+0.078	+0.117	+0.117	+0.117	+0.156	+0.156	+0.156	+0.156
ANGULAR TOLERANCE	2°	2°	2°	2°	2°	1.3°	1.3°	1.3°	1°	1°	1°	1°	1°

**TABLE 28: Millennium® TOLERANCES - RADIAL, AXIAL, ANGULAR**

SIZE	M00	M0	M1	M2	M3	M4	M5	M6	M7	M8	M9	M10	M11	M12
DISTANCE BETWEEN HUBS "E"	.060	.075	.075	.075	.075	.200	.200	.200	.200	.200	.200	.200	.200	.250
RADIAL TOLERANCE (TIR)	.020	.040	.040	.040	.040	.060	.060	.060	.060	.060	.060	.080	.080	.105
AXIAL TOLERANCE:														
MINUS	.010	.010	.020	.020	.020	.040	.040	.040	.040	.040	.060	.100	.100	.100
PLUS	.030	.040	.040	.040	.040	.075	.100	.100	.100	.100	.100	.150	.150	.200
ANGULAR TOLERANCE (DEGREE)	2°	2°	2°	2°	2°	1°	1°	1°	1°	1°	1°	1°	1°	1°

**TABLE 29: BUSHINGS FOR A-SERIES®**

ATRA-FLEX SIZE	BROWNING SIZE	BROWNING BUSHING RANGE	QD SIZE	QD BUSHING RANGE**	(EXT) TAPER LOCKSIZE	TAPER LOCK RANGE	(INT) TAPER LOCK SIZE	TAPER LOCK RANGE
A0	G	.375 to .875	JA	.500 to 1.1875	1008	.500 to 1.000	N/A	N/A
A1	H	.375 to 1.500	H	.375 to 1.500	1108	.500 to 1.125	1108	.500 to 1.125
A2	P1	.500 to 1.750	SD	.500 to 1.9375	1615	.500 to 1.625	1210	.500 to 1.250
A3	P1	.500 to 1.750	SK	.500 to 2.500	2012	.500 to 2.125	1610	.500 to 1.625
A4	Q1	.750 to 2.6875	SF	.500 to 2.8125	2517	.500 to 2.500	2012	.500 to 2.125
A5	R1	1.125 to 3.750	F	1.000 to 3.9375	3020	.9375 to 3.000	2517	.500 to 2.500
A6	S1	1.6875 to 4.250	J	2.000 to 4.500	3535	1.8125 to 3.500	3535	1.1875 to 3.500
A7	S1	1.6875 to 4.250	M	2.000 to 5.500	4545	1.9375 to 4.500	4040	1.4375 to 4.4375
A8	U1	3.750 to 5.500	N	2.4375 to 6.000	5050	2.4375 to 5.000	4545	.9375 to 4.500
A9	W1	3.750 to 7.4375	P	3.4375 to 7.000	6050	4.4375 to 6.000	5050	2.4375 to 5.000
A11	W1	3.750 to 7.4375	W	4.000 to 8.000	7060	4.9375 to 7.000	6050	4.4375 to 6.000

A-6 thru A-11 consult factory for availability of bushings not listed. Hubs can be machined for all types of different locking devices, consult factory.  
 \*Dimensions and overall length of couplings will change with bushed hubs. If dimensions are critical please refer to factory.

**TABLE 30: BUSHINGS FOR Millennium®**

ATRA-FLEX SIZE	BROWNING SIZE	BROWNING BUSHING RANGE	QD SIZE	QD BUSHING RANGE**	(EXT) TAPER LOCKSIZE	TAPER LOCK RANGE	(INT) TAPER LOCK SIZE	TAPER LOCK RANGE
M0	G2	.375 to 1.000	JA	.500 to 1.250	1008	.500 to .5625	N/A	N/A
M1	H	.375 to 1.500	SH	.500 to 1.6875	1108	.500 to 1.125	1108	.500 to 1.125
M1H	P1	.500 to 1.750	SH	.500 to 1.6875	1215	.500 to 1.250	1210	.500 to 1.250
M2	P1	.500 to 1.750	SDS	.500 to 2.000	1815	.500 to 1.6875	1310	.500 to 1.375
M3	B	.500 to 2.4375	SK	.500 to 2.500	2012	.500 to 2.125	1610	.500 to 1.625
M4	Q1	.750 to 2.6875	SF	.500 to 2.9375	2525	.500 to 2.500	2012	.500 to 2.125
M5	S1	1.6875 to 4.250	F	1.000 to 4.000	3020	.9375 to 3.000	3020	.9375 to 3.000
M6	S1	1.6875 to 4.250	J	2.000 to 4.500	4040	1.4375 to 4.4375	3535	1.1875 to 3.500
M7	U1	3.250 to 5.500	M	2.000 to 5.500	6050	2.4375 to 5.000	4040	1.4375 to 4.4375
M8	U1	3.250 to 5.500	N	2.4375 to 6.000	6050	4.4375 to 6.000	4545	1.9375 to 4.500
M9	W1	3.750 to 7.4375	P	3.4375 to 7.000	7060	4.9375 to 7.000	5050	2.4375 to 5.000
M10	W1	3.750 to 7.4375	W	4.000 to 8.000	8065	5.4375 to 8.000	6050	4.4375 to 6.000
M11	W2	3.750 to 7.4375	W	4.000 to 8.000	8065	5.4375 to 8.000	6050	4.4375 to 6.000
M12	Y0	6.000 to 10.000	S	5.500 to 10.000	10085	7.000 to 10.000	8065	5.4375 to 8.000

M-6 THRU M-12 - Refer to factory for availability of bushings not listed. Hubs can be machined for all types of locking devices, refer to factory.  
 \*Dimensions and overall length of couplings will change with bushed hubs. If dimensions are critical please refer to factory.



Refer to horsepower capacity at various RPM on page 4 for Millennium® (100 RPM column), horsepower capacity at various RPM on page 10 for A-SERIES® (100 RPM column), and page 18 for high torque low RPM applications (100 RPM column).

( constant multiplier )

**COUPLING SELECTION FORMULA:**

**METHOD:**

Data needed to correctly select coupling size

- (1) H.P. of driver (N)
- (2) R.P.M. of driver (n)
- (3) Service coefficient (k)

(A) Use figures obtained from graph tables 18, 19 and 20 for determining "K"  
 $K = F1 \times F2 \times F3$

- (4) Shaft and keyway size of driver and driven equipment.

$$100 \times K \times \frac{N}{n} = \text{Adjusted Horsepower}$$

**EXAMPLE:**

- Electric Motor - 50 H.P.
- RPM - 1750
- Driven equipment - centrifugal pump
- Working 24 hours per day
- Shaft - 17/8 x 21/4

$$K = F1 \times F2 \times F3 \text{ or } 1.3 \times 1.0 \times 1.0 = (1.3)$$

$100 \times 1.3 \times 1750 = 3.71 \text{ H.P.} = \text{Adjusted Horsepower}$  - go to TABLE 2 for Millennium® & TABLE 8 for A-SERIES®,\* always use RPM (100) column and follow down to Continuous Horsepower equal to or greater than Adjusted Horsepower (3.71). Select size A-3 or M-2.

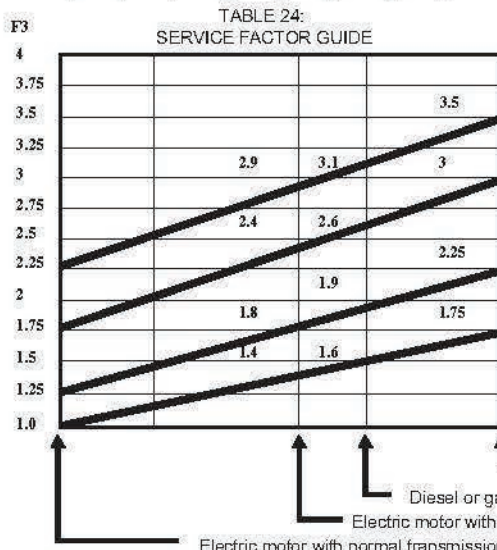
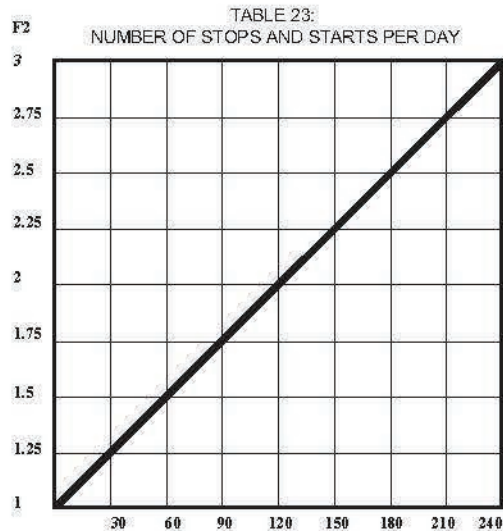
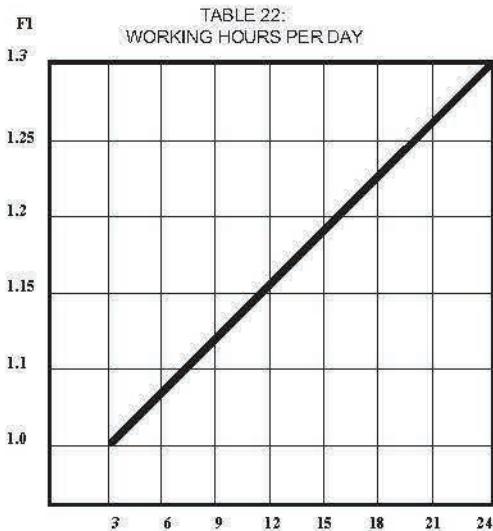

Stone grinders, slow beaters, sheet metal press cutters, pumps and piston compressors without fly-wheel and excavators.

Fast stone grinders, metal brushes, drilling machines, mixing machines, driers, pumps and compressors with fly-wheel.

Trashers, machine tools working uneven directions, shakers, elevators and conveyors.

Machine tools, pumps, centrifugals, ventilators expel - airs.

Diesel or gas engine with 1 and 3 cylinders.

Diesel or gas engine with 4 or more cylinders.

Electric motor with high starting torque.

Electric motor with normal transmission or turbine.



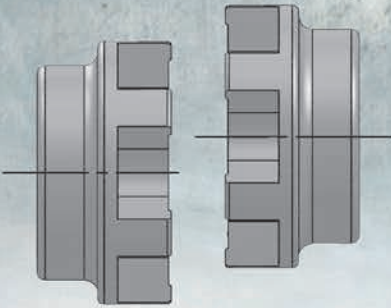

### **(1) RADIAL/PARALLEL**

THE FREE MOVEMENT OF THE ATRA-FLEX INSERT ACCOMMODATES PARALLEL MISALIGNMENT, AND STILL MAINTAIN FULL SHOCK AND VIBRATION DAMPING.

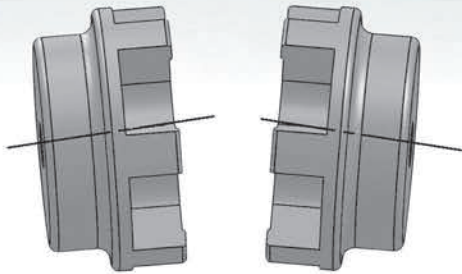

### **(2) ANGULAR**

ATRA-FLEX INSERT ALLOWS THE ROCKING AND SLIDING ACTION OF THE HUBS UNDER AN ANGULAR MISALIGNMENT, WITHOUT ANY LOSS OF POWER THROUGH THE RESILIENT ADIPRENE INSERT.

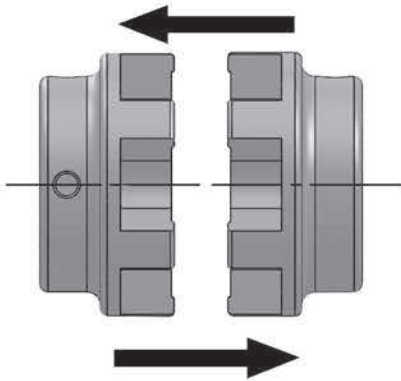

### **(3) AXIAL**

ATRA-FLEX INSERT ALLOWS UNRESTRAINED END FLOAT FOR BOTH DRIVING AND DRIVEN MEMBERS.

### **NOTE: ALIGNMENT !!**

A FLEXIBLE COUPLING IS NOT DESIGNED TO COMPENSATE FOR EXCESSIVE MISALIGNMENT. ITS PURPOSE IS TO PERMIT SLIGHT MOVEMENT OF PUMP OR DRIVER SHAFTS OR ANY DRIVEN EQUIPMENT WHILE TRANSMITTING POWER. EXCESS MISALIGNMENT CAN CAUSE SHORT COUPLING LIFE DUE TO SLIDING AND WORKING ACTION OF COUPLING CONNECTORS. MODERN MACHINERY OPERATES AT EVER INCREASING SPEEDS; EVEN MINOR ALIGNMENT ERRORS LEAD TO HIGH VIBRATION ON BEARING LOADS RESULTING IN MACHINERY DAMAGE AND PRODUCTION DOWNTIME.

### **ATRA-FLEX® SOLVES:**

MISALIGNMENT PROBLEMS BY A "FAIL SAFE" METHOD. IF YOU SHOULD EXCEED OUR ALIGNMENT TOLERANCES (WHICH IS THE MAXIMUM YOUR EQUIPMENT SHOULD BE SUBJECTED TO WITHOUT SUBSTANTIAL LOSS OF EQUIPMENT LIFE) THE RING WILL WALK OFF THE INSERT TO PHYSICALLY INDICATE A GROSS MISALIGNMENT. CORRECT THE MISALIGNMENT AND THE RING WILL STAY IN PLACE. AT THAT TIME, YOU HAVE GUARANTEED YOURSELF MAXIMUM LIFE OUT OF YOUR ROTATIONAL EQUIPMENT WHICH EQUALS = \$\$\$\$ DOLLARS \$\$\$\$ SAVED!!!



**CORPORATE HEADQUARTERS**

**ATR SALES, INC.**

**110 E. GARRY AVE  
SANTA ANA, CA 92707  
PH: 800.443.6613 / FAX: 800.988.9896**

**Distributed throughout the World**



**Sold through stocking distributors:  
your local distributor is:**



**Distributorship inquiries welcome  
Please contact your nearest regional office**